

# TT-2000-D2000

## Ticket Eater™ with AP-100 Logic Board



# Table of Contents

Initial Setup.....	3
Handling Messages on the Door Display .....	4
DL Ticket Eater Manager Software .....	5
Changing Options without Software .....	7
Performing Functions without Software .....	11
Maintenance Checklist .....	12
Blade Adjustment & Replacement.....	15
Printers and Loading Paper .....	17
Ticket Specifications .....	19
Diagnostic LEDs .....	20
Trouble-Shooting.....	21
Mechanical Drawings.....	23
Sensor Boards .....	30
Electrical Schematics.....	33
Warranty Information .....	36

## Initial Setup

---

This manual is for the TT-2000 Ticket Eater™ with an AP-100 logic board. Do not use this manual if you have an earlier version logic board. Earlier version boards lack a USB connector and are not labeled “AP100”.

As part of the initial setup there are several options in the Ticket Eater logic board that must be configured for your situation. These settings can be made with the DL Manager software or by using buttons inside the Ticket Eater. Later sections in this manual explain both methods.

The initial options that you must set are:

1. Printer Model. Refer to appendix A for more information on the printers. When using the buttons, this is option 17 in group 99 1.
2. If your sensor board is Rev. 1 to 4 then set the Rev to 4; otherwise set it to 5. Refer to appendix C for more information on the sensor boards. When using the buttons, this is option 31 in group 99 3.
3. The Barcoded / Holes-Only option must agree with your tickets and sensor board. If this setting is wrong the Ticket Eater will not count correctly. When using the buttons, this is option 30 in group 99 3.
4. If you are using barcoded tickets the Ticket Eater must learn the barcode pattern on the tickets. When using the buttons, use the options in group 99 4.
5. Receipt message (DL Manager software is required to change the message).

### **Switching Door Displays**

The control signals for the 4 digit and 5 digit seven segment door displays are different than the control signals for the dot matrix door display. Since the normal procedures for changing options use the door display there is a special procedure for changing between the dot matrix and the seven segment displays.

1. Start with the power off.
2. Press and hold the SW1 button on the logic board and the red button in front of the logic board.
3. While holding the buttons turn the machine on.
4. Release SW1 and the red button. If the logic board was previously set for a dot matrix display it will now be set for a 5 digit display. If it was previously set for a 4 or 5 digit display it will now be set for a dot matrix display.

If you have a 4 digit display, first use this procedure to get the logic board into a 5 digit display mode. At this point you will be able to see the display. Then use the procedures explained in the chapter on Changing Options Without Software to change option 36 to 4.

## Handling Messages on the Door Display

---

There are four messages that can appear on the display on the door. DL Manager software can change the wording of these messages. Card swipe equipped systems may have additional messages.

1. **Print**

This is a normal informational message.

2. **Printer Error**

Typical causes of this error are out of paper, printer turned off, paper improperly loaded, printer is off-line (does not apply to all printers) , and a defective printer.

3. **Call For Help**

This message is usually caused by tickets stuck in the transport mechanism. After fixing the problem, clear the error by pressing the red button or by turning the ticket eater off and back on.

4. **Bin Full**

This message means that the trash can needs emptied. If your Ticket Eater has a full-bucket sensor then emptying the trash can clears the error. In machines without a full-bucket sensor the message is triggered by the number of tickets that have been processed. Press the red button to clear the error and reset the count.

Option 25 in group 99 2 tells the ticket eater to use a full-bucket sensor. Option 26 in group 99 2 sets the capacity of the trash can.

If you set option 26 to zero and you are not using a full bucket sensor, it will disable the “Bin Full” message.

If you empty the trash can before the full count is reached, reset the bucket count with Function Mode 3 (see the section “Performing Functions without Software”) or with the DL Manager software.

Machines with card swipe systems may also show these messages:

1. **Full Count – Scan Card or Print**

The maximum possible count is limited by the number of digits in the door display. When this count is reached, the Ticket Eater will stop and display this message. After the card is scanned or a receipt is printed the Ticket Eater will return to normal operation.

2. **Sending Data**

This is a normal informational message.

3. **Data Send Error – Call for Help**

Problems with the card swipe system or the communication between the card swipe system and the logic board will cause this message. Fix the problem and re-start the Ticket Eater.

## DL Ticket Eater Manager Software

DL Ticket Eater Manager software is the preferred way to manage your TT-2000 Ticket Eater with AP-100 main logic board. This section of this manual covers that. Some management functions can also be done without the software by using buttons inside the TT-2000. The next section of this manual covers those procedures.

DL Ticket Eater Manager software requires Windows XP or later.

The software uses USB 2.0 to connect to the ticket eater. (USB 1.x is not supported.) To make this connection:

1. Open the top door of the Ticket Eater .
2. Pull out the safety switch. This turns the Ticket Eater on with the door open. The red and green LED's on the main logic board should be on.
3. Connect a USB cable between the computer and the USB jack on the main logic board.
4. Use the software to configure and manage the Ticket Eater.

The software has various entries organized into 5 tabs (circled in black). The toolbar (circled in white) has two buttons for opening and saving configuration files, two buttons for transferring configurations between the software and the Ticket Eater, and five buttons for controlling the Ticket Eater.

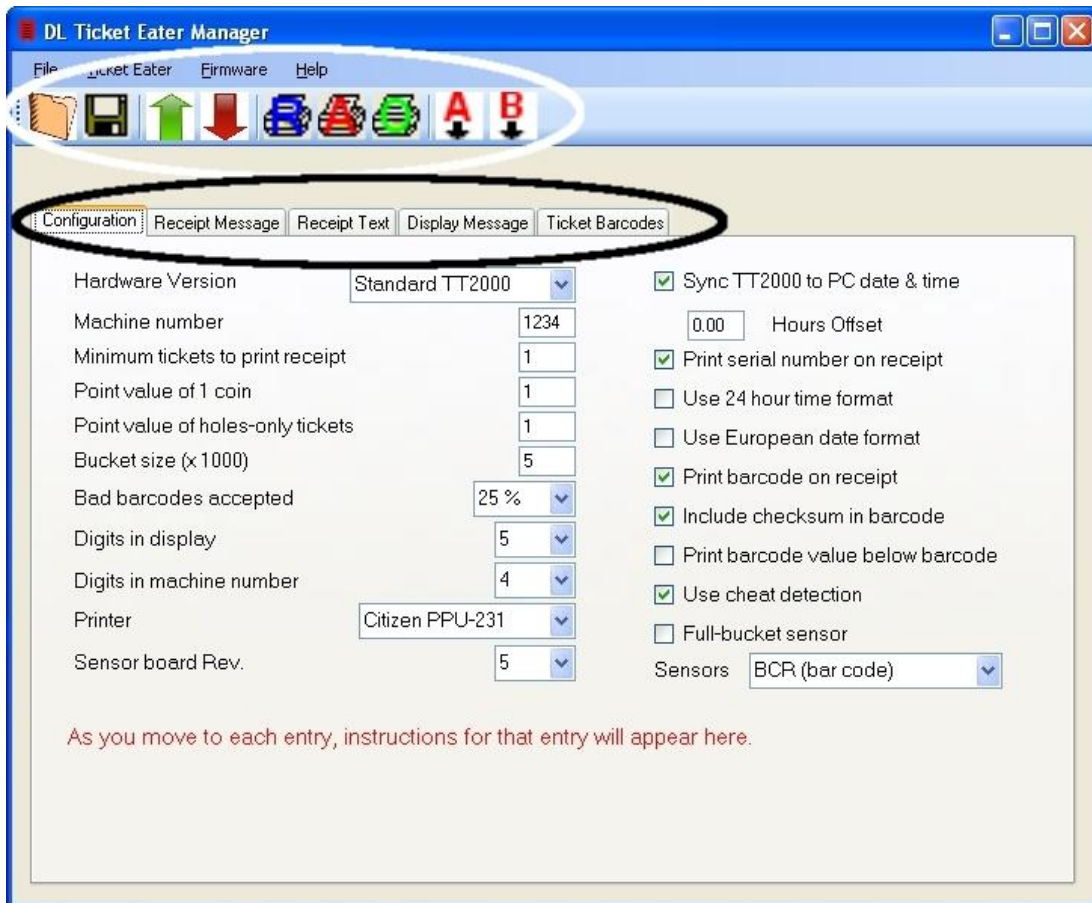

A Ticket Eater configuration can exist in 3 places:

1. In a Deltronic Labs Ticket Eater
2. In a configuration file on your computer.
3. In the entry blanks of the software.

Using the software you can:

1. Transfer a configuration between the program entry blanks and a Ticket Eater.
2. Edit a configuration.
3. Save a configuration to a file and retrieve a configuration from a file.
4. Perform management functions.
5. Install updated programming in a Ticket Eater.

### ***Transferring Configurations to and from a Ticket Eater***

First, connect a USB cable as described above. Then use the commands on the Ticket Eater menu or buttons on the toolbar to transfer the configuration.

### ***Editing a Configuration***

Use the entry blanks to edit a configuration. As you move to each entry blank, instructions for that entry appear. Some entries are applicable only to certain hardware.

### ***Save and Open Configuration Files***

Use the commands on the File menu or buttons on the toolbar to save and open configuration files. These operations transfer a configuration between the file and the entry blanks.

### ***Management Functions***

Use commands on the Ticket Eater menu or buttons on the toolbar to:

1. Print a duplicate of the last receipt printed.
2. Print an audit report on the Ticket Eater's printer.
3. Print an options report on the Ticket Eater's printer.
4. Reset the audit counters.
5. Reset the bucket counter (when not using a full-bucket sensor).

### ***Install Updated Programming***

Use the Upload New Firmware command on the Firmware menu to install new programming in the ticket eater logic board. You should do this only when instructed to do so by Deltronic Labs tech support.

## Changing Options Without Software

DL Ticket Eater Manager software is the preferred way to manage your TT-2000 Ticket Eater with AP-100 main logic board. The previous section of this manual covers that. Some options can also be changed without the software by using buttons inside the TT-2000. This section covers those procedures. Changing any of the words printed on the receipt can only be done with the software.

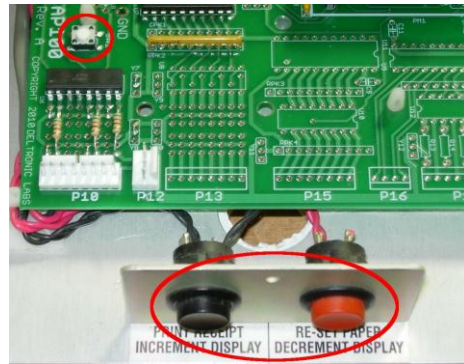

These procedures use the two buttons mounted in front of the logic board, the **SW1** button on the logic board, and the 7 segment display on the door. The **RUN/PRG** jumper is not used. It must stay in the **RUN** position. **Leaving the jumper in the PRG position will drain battery.** To enter the options mode:

1. Open the top door of the Ticket Eater.
2. Pull out the safety switch. This turns the Ticket Eater on with the door open. The red and green LED's on the main logic board should be on.
3. Wait for the display to finish the power-up test and enter the "Snake" mode.
4. Push the **SW1** button.
5. The display will show **99 0**. You are now in Options Mode.

In Options Mode the first number (99 in this case) shows the number of the option that you are working with. The second number (0 in this case) shows the option's value. Pressing the red or black button in front of the logic board changes the option's value. Pressing both buttons at the same time accepts the currently displayed value.

Button	Function
Black	Increase the Value
Red	Decrease the Value
Both	Accept the Value

The options are organized into groups. **99** is a special number which indicates that you are selecting a group of options to work with. When you select a group, the first option in that group is displayed. As you accept each option by pressing both buttons together, the next option is displayed. After the last option is accepted you are returned to **99** so that you can select another group. If you turn off the machine before you finish viewing a group, your changes to that group will be lost.

Group 99 0		
Option Number	Function	Values
1	Year	0 to 99
2	Month	1 to 12
3	Date	1 to 31
4	Day	1 to 7(Sunday to Saturday)
5	Hour	0 to 23
6	Minute	0 to 59

Group 99 1		
Option Number	Function	Values
10	Print serial number on receipt	0 = No, 1 = Yes
11	Time format	0 = 24 hour 1 = AM / PM
12	Receipt (The second copy is for store use. It does not have the message on it.)	0 = 1 copy, no barcode 1 = 1 copy, middle barcode 2 = 1 copy, bottom barcode 3 = 2 copies, no barcode 4 = 2 copies, middle barcode 5 = 2 copies, bottom barcode
13	Include checksum in barcode	0 = No, 1 = Yes (see Note)
14	Print text below barcode	0 = No, 1 = Yes
15	Date format	0 = mm/dd/yy 1 = dd/mm/yy
16	Minimum tickets to print receipt	1 to 99
17	Printer ID	0 = PPU-231 1 = Star TUP-482 2 = Custom VKP-80II

NOTE: Some swipe systems and some scan systems will get ticket counts that are approximately ten times too small or too large if option 13 is not set to their preference.

Group 99 2		
Option Number	Function	Values
20	Machine number: Thousands	0 to 9
21	Machine number: Hundreds	0 to 9
22	Machine number: Tens	0 to 9
23	Machine number: Ones	0 to 9
24	Number of digits in machine number	3 to 4
25	Full bucket sensor (This sensor can also be used to catch cheating by detecting tickets falling into the trash).	0 = No sensor 1 = Full and anti-cheat 2 = Full only 3 = Anti-cheat only
26	Bucket capacity (in 1000's of tickets)	1 to 99



Full Bucket Sensor mounted on Ticket Chute Cover

Group 99 3		
Option Number	Function	Values
30	Sensor Board	0 = BCR-1000 1 = HO-1000 2 = BCR as HO (see NOTE) 3 = DS-2000 4 = BCR-2000 5 = HO-2000
31	Sensor board revision	4 to 5
32	Use sensor board cheat detection	0 = No, 1 = Yes
33	Bad barcode tolerance	0 = 0% (most strict) 1 = 25% 2 = 50% 3 = 75% 4 = 100% (rejects nothing)
34	Points value of Holes-Only ticket	1 to 99
35	Points value of one coin	0 to 99
36	Digits in door display	4, 5, 8 (see page 3)
37	Power Mains	0 = 60 Hz, 1 = 50 Hz

NOTE: BCR sensor boards are used to count barcoded tickets. HO sensor boards are used to count holes-only tickets. Barcode sensor boards can be used to count holes-only tickets, but there is **NO CHEAT DETECTION** when used this way. This should only be done in an emergency situation. Some barcode sensor boards can be configured by means of jumpers on the board to work as a holes-only sensor board. In this case choose HO. In this case you will have cheat detection.

Group 99 4		
Option Number	Function	Values
41	Points value for barcode #1	0 to 99
42	Points value for barcode #2	0 to 99
43	Points value for barcode #3	0 to 99
44	Points value for barcode #4	0 to 99
45	Points value for barcode #5	0 to 99
46	Points value for barcode #6	0 to 99
47	Points value for barcode #7	0 to 99
48	Points value for barcode #8	0 to 99

Group **99 4** sets the points value for barcoded tickets. When using barcoded tickets, the Ticket Eater accepts only tickets that have the correct barcode. To do this it must first learn the barcode pattern on the tickets. It can learn 8 different barcodes, each with its own point value.

To teach the Ticket Eater a barcode:

1. Go to one of the option numbers in group **99 4**.
2. Use the black and red buttons to adjust the point value.
3. Feed the Ticket Eater a strip of seven tickets.
4. After reading the tickets the ticket eater will display a series of numbers which represent the barcode pattern. (If these numbers are all zeros, the reading failed.)

5. To accept and record the reading, press both buttons together. To reject the reading turn off the machine without pressing both buttons.

Group **99 5** performs the special function of clearing the audit counters. When you select **99 5**, the display continues to show **99 5**, but it blinks. At this point you can press the red button to clear the audit counters, or the black button to cancel clearing.

Group **99 6** exits the options mode.

## Performing Functions Without Software

---

DL Ticket Eater Manager software is the preferred way to manage your TT-2000 Ticket Eater with AP-100 main logic board. A previous section of this manual covers the software. Some management functions can also be done without the software by a special Function mode. This mode uses buttons inside the TT-2000. This section covers the Function mode.

These procedures use the two buttons mounted in front of the logic board, the **SW1** button on the logic board, and the 7 segment display on the door. To enter the Function mode:

1. Open the top door of the Ticket Eater.
2. While pressing **SW1**, pull out the safety switch. This turns the Ticket Eater on with the door open and starts the Function mode.
3. The display will show **FUNC0**.
4. Use the black and red buttons to change the function number.
5. Press **SW1** to select the function.

Button	Function
Black	Increase the function number
Red	Decrease the function number
SW1	Select the function

Function	Action
0	Exit the function mode
1	Print a duplicate receipt
2	Print an audit report
3	Reset the bucket meter
4	Print an options report

## Maintenance Checklist

1. To avoid damaging the sensor board, remove it before releasing or removing the Guide Assembly.
2. When the Guide Assembly is released or the entire assembly is removed for servicing or cleaning, follow this procedure to replace it:

- a. The motor assembly has extra O rings installed on both the Lower Drive Roller Shaft and the Motor Shaft. Before replacing the guide assembly, make sure the O rings are not riding on the sides of the rollers. They should be next to the Side Plates and away from the rollers.

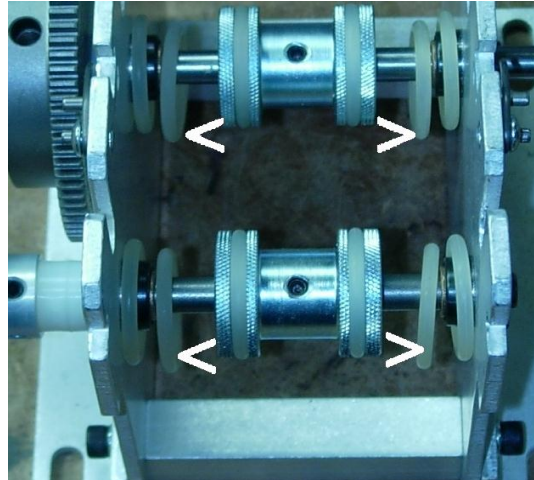

- b. Place the Rear Idler Roller (the one closest to the cutter) into its slots in the side plates.

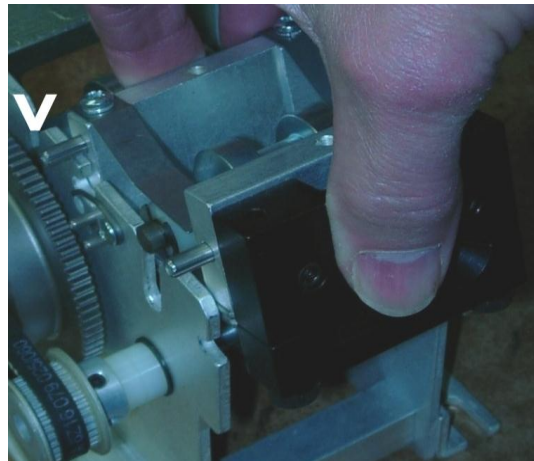

- c. Let the Front Idler Roller Shaft drop into its slots in the side plates.

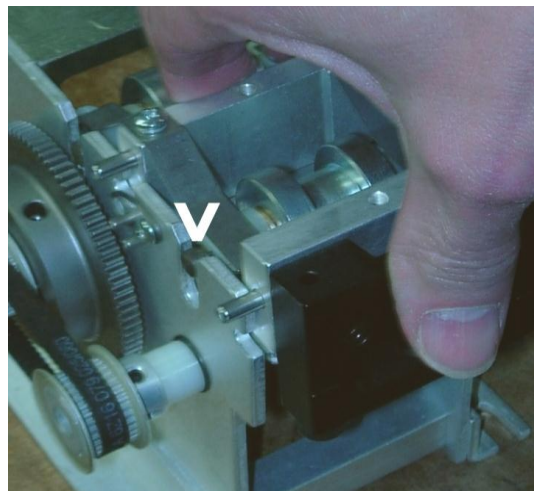

- d. Pull the **Guide Assembly** slightly towards you to allow the pins to drop into their slots.

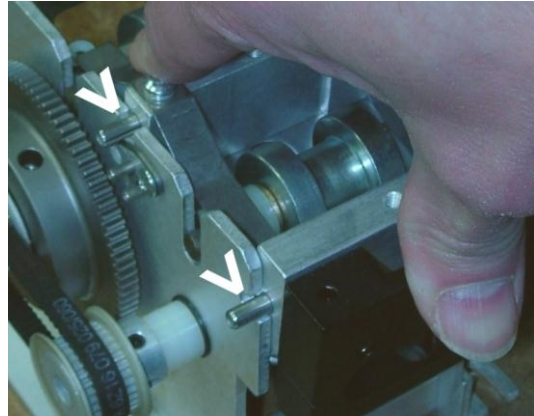

- e. Push the **Guide Assembly** towards the cutter and away from you until it stops, and then press down firmly on the **Spring Spacer Block** (it has the Phillips head screws) to load the springs. The springs (black arrow) should lock the **Rear Pins** (white arrow) into their slots. See the mechanical drawings.

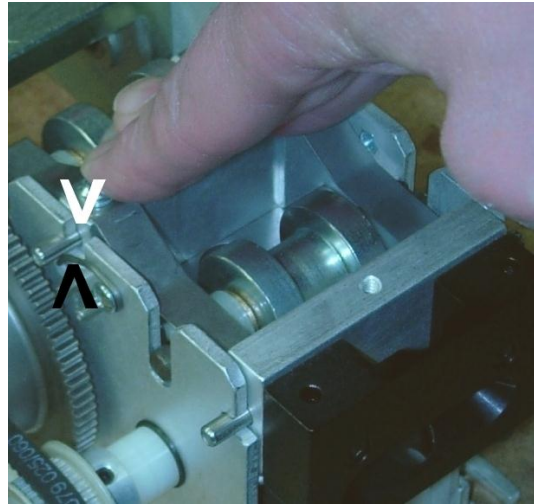

3. When replacing the **Cutter**, make sure that it is seated all the way down so that its gear meshes with the large gear on the **Driveshaft**.
4. Clean the optical sensors on the sensor board.
  - a. Carefully unplug the cable from the board.
  - b. Remove two thumbscrews.
  - c. Lift the board straight up.
  - d. Turn the board over. Carefully wipe the sensors with a soft cloth or alcohol swab.
  - e. Replace the board, thumbscrews, and cable.
5. Check that the **Cutter Blade** is tight on its shaft. The shaft has a flat. Tighten the cutter's set screw against the flat.
6. Check the **Cutter Blade** for a build-up of dirt or adhesive from the paper. Clean with an alcohol swab or solvent.

7. Check that the **Large Gear** is tight on the **Driveshaft**. The shaft has a flat. Tighten the gear's set screw against the flat.
8. Make sure the **Chute Cover** is pushed down all the way. The **Chute Cover** presses an interlock switch located under the shelf. The switch interrupts power to motor when the **Chute Cover** is open. A bent **Chute Cover** can fail to activate the switch.
9. Keep the entire shelf area clean of dust. The optical sensors are most affected by dust build-up.

While cleaning, **TURN OFF THE POWER.**

Do not use a metal ended vacuum to clean any circuit board. A can of compressed air or an air compressor is recommended for cleaning circuit boards.

After cleaning replace the covers. They are there for safety and to protect the circuit boards. Metal objects like tokens or tools dropped on the boards can cause short circuits and damage the boards.

10. Do not block the exhaust fan on the rear and the vents on the side. Allow at least 6 inches (15 cm) of clearance.
11. If you are getting a message on the display instead of a ticket count or the snake mode, refer to the section on "Handling Messages on the Door Display".

## Blade Adjustment & Replacement

### **Stationary Blade Adjustment**

The Ticket Eater blade is adjusted at the factory. As the blade wears, adjusting it so that it is closer to the cutter will extend its life. To adjust the blade, follow these steps:

1. Make sure the **POWER IS OFF** and the cutter is not rotating.
2. Pull straight up to remove the cutter assembly from guide housing assembly
3. Set the cutter assembly on a spacer or the edge of your workbench so that you can access the blade screws and turn the flywheel.

**CAUTION:** Even a dull blade is sharp enough to cut your fingers. Keep them away from the cutter and the blade.

4. Use a 7/64 inch hex wrench to loosen the socket head attachment screws that hold the stationary blade. Loosen them so that they can be turned with your bare fingers, but do not remove them.

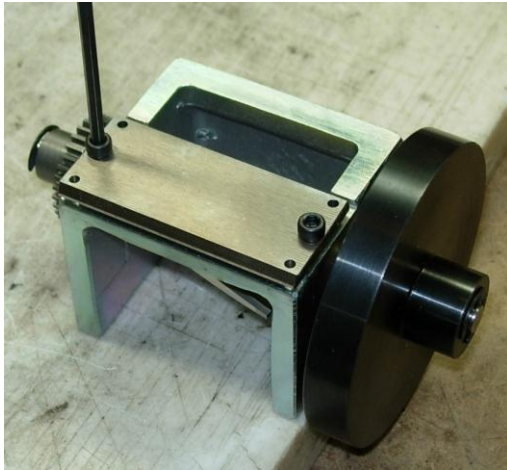

Socket Head Attachment Screw

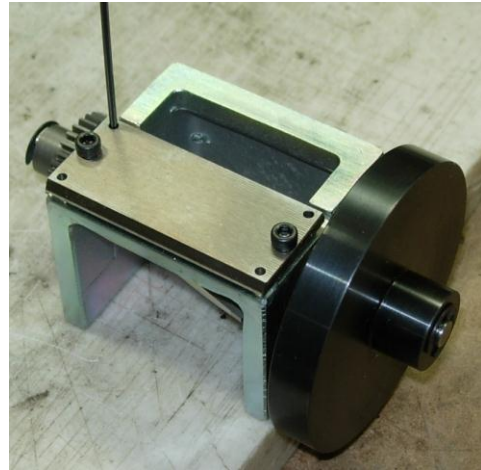

Adjustment Set Screw

5. Insert a 1/16 inch hex wrench through the top clearance hole of the stationary blade into the set screw.
6. Turning the set screw clockwise will move the blade closer to the cutter. Slowly spin the flywheel while turning the set screw clockwise. As the blade nears the cutter edge you will start to hear and feel the blade touch the cutter as you rotate it. If you go too far the cutter will not turn freely. Adjust both the left and right sides so that you get no contact and can see no light between the cutter and the blade..
7. Slowly tighten the screws that hold the stationary blade while rotating the cutter and checking the contact adjustment. As the screws are tightened they will pull the blade away from the cutter. Use the adjustment screws to compensate.
8. Re-install the cutter assembly in the machine. Make sure that it is seated all the way down so that its gear meshes correctly with the gear on the guide housing assembly.

## ***Stationary Blade Replacement***

The Ticket Eater blade has two edges. When one edge has worn to the point that it can not be adjusted, it can be flipped around to use the other edge. To flip the blade or replace the blade, follow these steps:

1. Make sure the **POWER IS OFF** and the cutter is not rotating.
2. Pull straight up to remove the cutter assembly from guide housing assembly
3. Set the cutter assembly on a spacer or the edge of your workbench so that you can access the blade screws and turn the flywheel.

**CAUTION:** Even a dull blade is sharp enough to cut your fingers. Keep them away from the cutter and the blade.

4. Use a 7/64" hex wrench to remove the screws that hold the stationary blade (see photo on previous page).
5. Remove the blade, but leave the adjustment screws in place.
6. Flip the blade around to use the other edge, or use a new blade. Install the blade being careful not to get the bevel backwards. The wider side of the blade should be against the frame.
7. Follow the instructions on the previous page to adjust the blade.

## Printers & Loading Paper

---

### ***Star dot matrix printer***

This printer is used in some older machines. The printer is mounted on the inside of the top door.

The printer control board (circled in photo) has 3 LEDs. The top LED is a green “power on” indicator. The middle LED is a red “error” indicator. It is lit when there is a problem such as out of paper.

The bottom LED is a green “on line” indicator. The printer control board has two switches. The top switch is an on-line / off-line toggle. The bottom switch feeds paper.

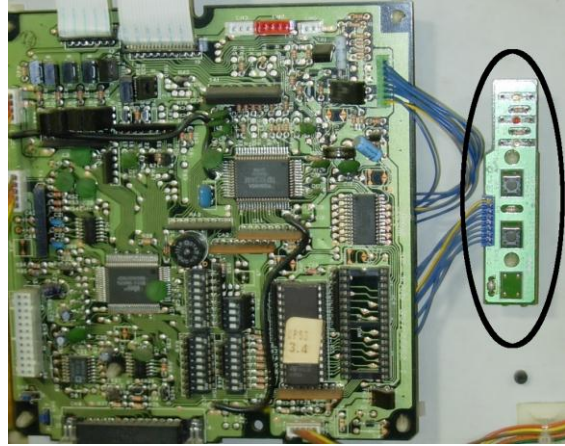

### ***Citizen thermal printer***

Most Ticket Eaters have this printer. The printer sits on shelf inside the cabinet. On the side of the printer are a paper-feed switch and an on/off toggle switch (circled in photo). Please refer to the printer manual for further instruction on printer care and functions. Refer to the next page for paper loading instructions.

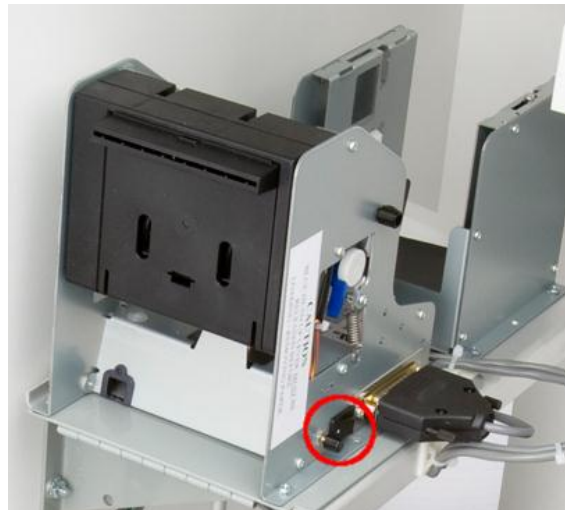

#### 4.3 Inserting the Paper



- 1) Be sure to use the specified paper roll.
- 2) Use of non-specified paper may not guarantee the print quality, printing head life, presenter operation, and so on.
- 3) Do not insert a ragged or dog-eared end of the paper roll, because it could result in a paper jam or insertion error.

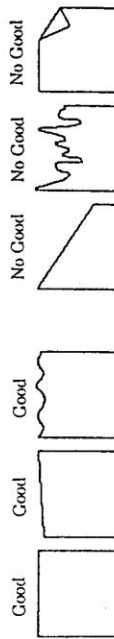

1. Cut the front end of the paper roll almost at a right angle.
2. Insert the paper roller of the paper holding unit into the core of the paper roll as shown in the figure on the next page.
3. Make sure the paper winding direction and put the paper roll onto the PHU.
4. Make sure that the power is turned on.
5. If there is still some paper remaining after a paper-out indication, eliminate the paper roll according to "4.4 How to Remove the Remaining Paper Roll."
6. Raise the head-up lever of the printer/presenter unit. (See the next page.)
7. Insert the front end of the paper roll straight into a paper insertion slot as shown in the figure on the next page, until the paper stops.
8. Put back the head-up lever. The paper is automatically pulled in by the platen roller to feed a constant amount of paper. (When auto-loading is enabled.) Remove the cut paper to enable printing.



- 1) If the paper roll is still slack, rewind the paper to remove the slack.
- 2) If the paper roll is tilted, raise the head-up lever to correct the paper roll position, or pull out the paper roll and set it again.
- 3) Do not hold or press the paper roll while printing, because it could cause a paper jam.
- 4) After the paper is set, the printer is made ready to start printing. Note that if data is remaining in the buffer, the printer will start printing after the paper is set.

\*IMPORTANT\* PAPER WIDTH CANNOT EXCEED 3.125 in. THERMAL PAPER ONLY

\*NOTE\* IF USING PAPER WITH TICKET EATER LOGO, PAPER IS LOADED OPPOSITE OF ABOVE (FROM BOTTOM)

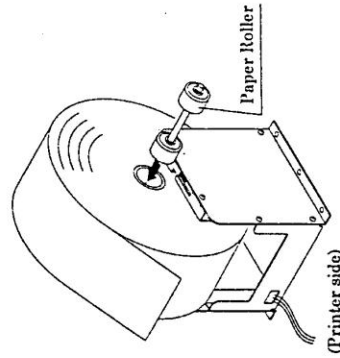
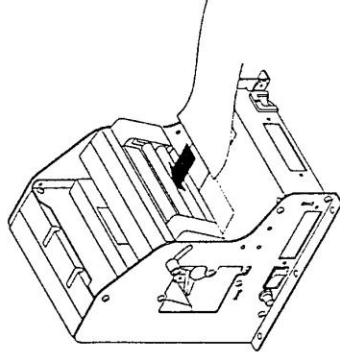

Paper Roller

(Printer side)

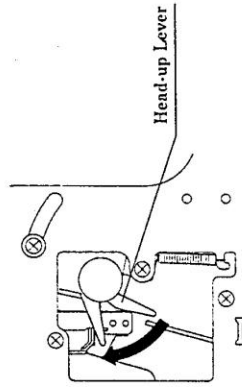

Head-up Lever

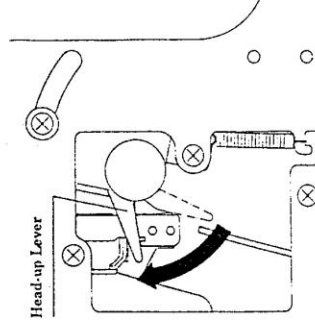

Head-up Lever

#### 4.4 How to Remove Remaining Paper Roll

1. Raise the head-up lever of the printer/presenter unit.
2. Gently pull out the paper from the printer/presenter unit. If the paper roll is still remaining, cut it just before the paper insertion slot before pulling it out.



- 1) Never take out paper with the head-up lever lowered, because it could damage the printing head.
- 2) The printer mechanism may be very hot just after printing, so be duly careful.

## Ticket Specifications

The Ticket Eater is designed to count industry standard tickets. These tickets are 1 5/32" wide by 2" long. They have a 1/4" diameter hole in the middle of the ticket which is centered on the perforation between tickets. For use in ticket dispensers they will also have a 1/4" diameter half hole on each side of the ticket at the perforation.

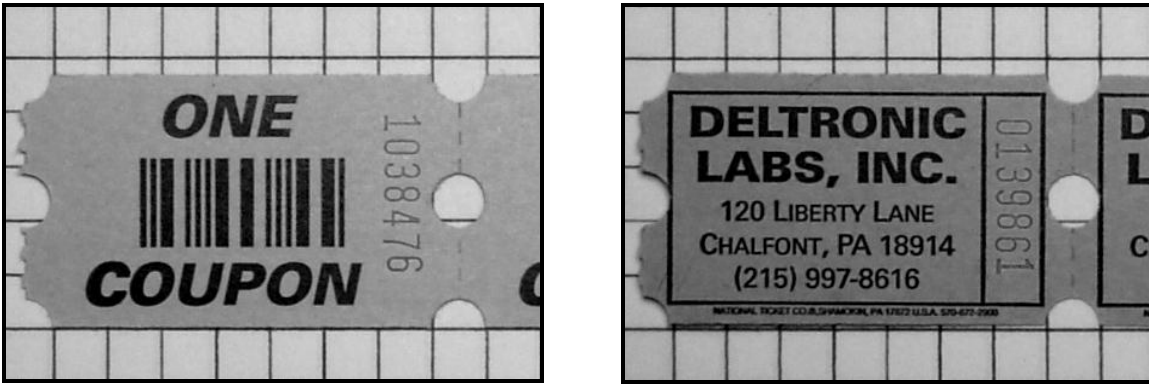

Barcoded and Holes-Only Tickets photographed on 1/4" grid.

The barcode on barcoded tickets is 4 digits of interleaved 2 of 5 code. This gives it 14 bars and 13 spaces. Overall dimensions of the barcode are 1" long x 1/2" wide. There are 18 thin bars/spaces and 9 thick bars/spaces. Thin bars/spaces are 1/45" thick. Thick bars/spaces are 3/45" thick.

The barcode bars should be printed with a dark color (black is preferred). The ink should be dense enough that no background color shows through the bars

The barcode must be printed on both sides of the tickets.

The barcode background color should not be a dark color such as dark brown, dark blue, dark gray, etc.

Keep the area between barcodes as clear of markings as possible. A light red sequence number is permitted. No other color is allowed.

## Diagnostic LEDs

The Ticket Eater has several diagnostic LEDs:

Location	Color	Indicates	Status
Logic Board	Red	+5 V Power	Normally On
Logic Board	Green	+12 V Power	Normally On
Motor Drive Board	Red	Motor Control Signal from Logic Board	Motor should be on when it is on
HO-1000 Rev. 1-4 D1	Red	Ticket detected	Off when front sensor sees ticket
HO-1000 Rev. 1-4 D2	Red	Ticket detected	On when middle sensor sees ticket
HO-1000 Rev. 1-4 D3	Red	Ticket Jam if off when don't have tickets	Off when rear sensors see ticket
BCR-1000 Rev. 1-4 Front	Red	Ticket detected	Off when front sensor sees ticket
BCR-1000 Rev. 1-4 Rear	Red	Ticket Jam if off when don't have tickets	Off rear sensors see ticket
HO-1000 Rev. 5 LED 1	Red	Ticket detected	On when middle front sensor sees ticket
HO-1000 Rev. 5 LED 2	Red	Ticket detected	On when right rear sensor sees ticket
HO-1000 Rev. 5 LED 3	Red	Ticket detected	On when left rear sensor sees ticket
HO-1000 Rev. 5 LED 4	Red	Ticket detected	Off when front sensor sees ticket
HO-1000 Rev. 5 LED 5	Red	Cheating	Flashes On when error is detected
HO-1000 Rev. 5 LED 6	Red	Ticket detected	On when middle rear sensor sees ticket
BCR-1000 Rev. 5 LED 1	Red	Cheating	Flashes On when error is detected
BCR-1000 Rev. 5 LED 2	Red	Ticket detected	Off when front sensor sees ticket
BCR-1000 Rev. 5 LED 3	Red	Ticket detected	On when middle sensor sees a bar in the barcode
BCR-1000 Rev. 5 LED 4	Red	Ticket detected	On when middle rear sensor sees ticket
BCR-1000 Rev. 5 LED 5	Red	Ticket detected	On when left rear sensor sees ticket
BCR-1000 Rev. 5 LED 6	Red	Ticket detected	On when right rear sensor sees ticket

## Trouble-Shooting Flowchart

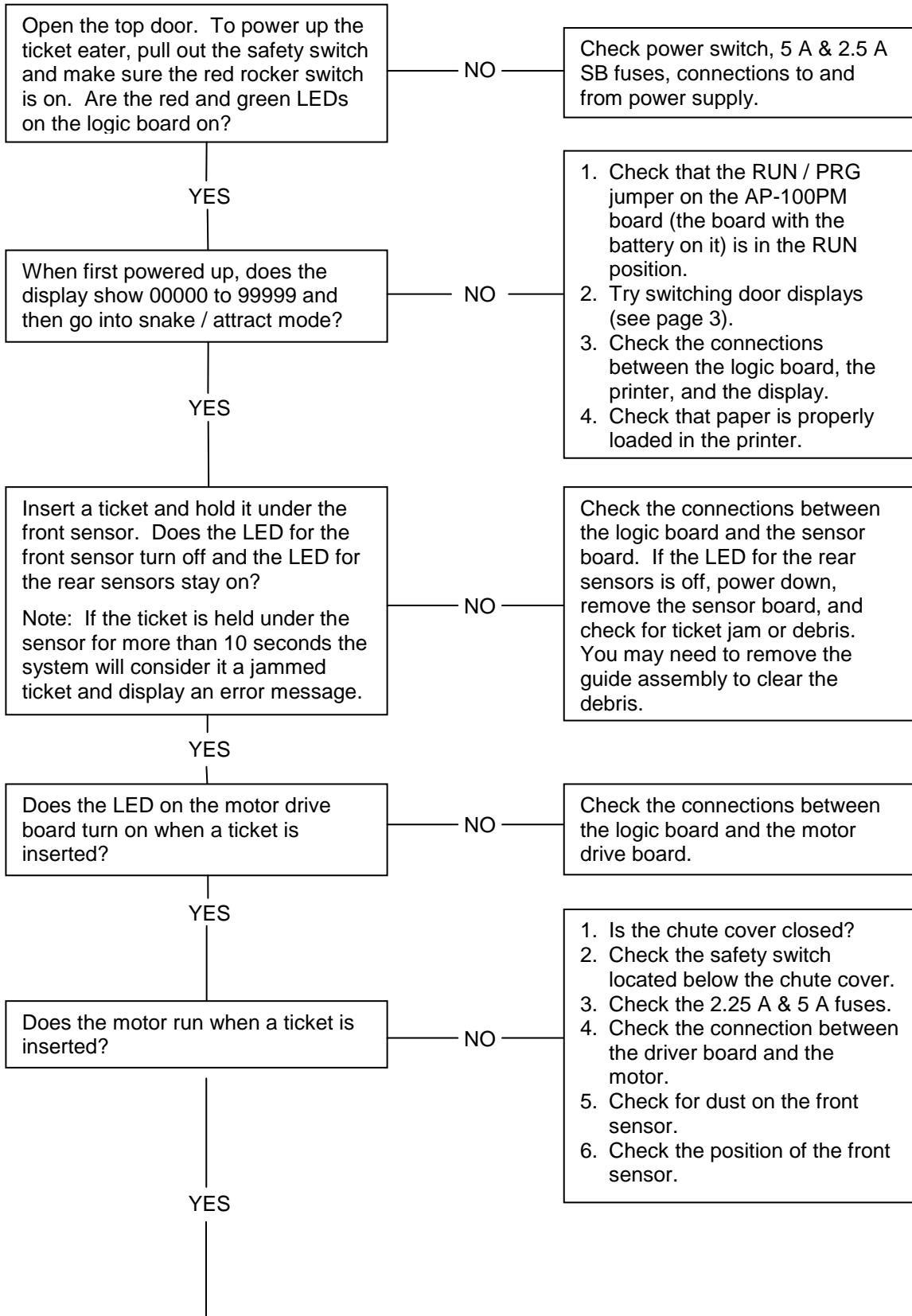

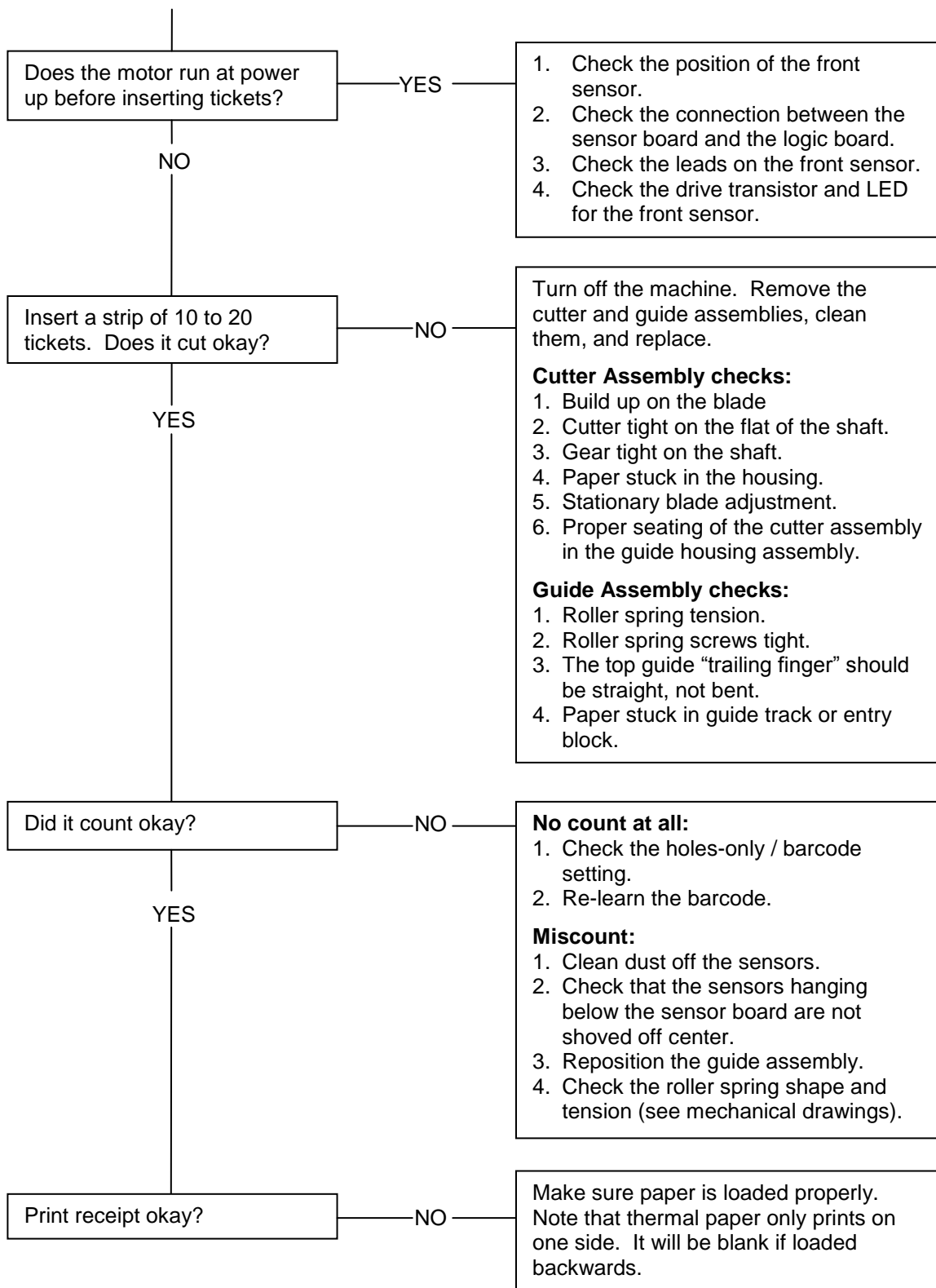

# Mechanical Drawings

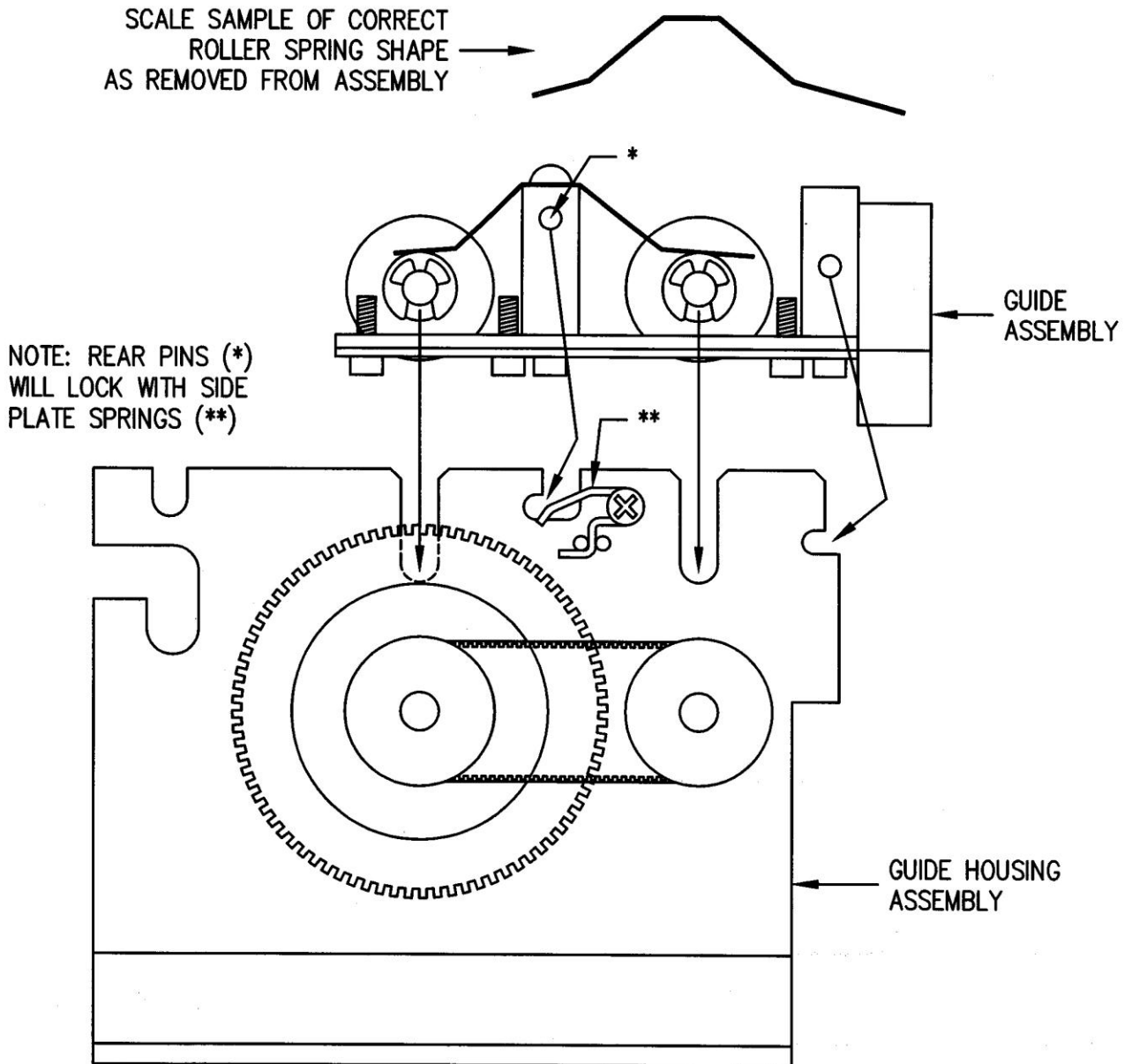

## CAUTION!

WHEN INSERTING GUIDE ASSEMBLY INTO GUIDE HOUSING ASSEMBLY, YOU MUST ALIGN THE TOP ROLLER SHAFTS IN THE APPROPRIATE SLOTS BEFORE PUSHING THE GUIDE ASSEMBLY DOWN AND FORWARD.

IMPROPER PROCEDURE MAY CAUSE DAMAGE TO THE ROLLER SPRINGS.  
REFERENCE THE MAINTENANCE TIPS AND TROUBLESHOOTING GUIDE.

ITEM	QTY	DL PART #	DESCRIPTION
1	1	GUID-TTBOT//	TICKET GUIDE (BOTTOM)
2	1	GUID-TTTOP//	TICKET GUIDE (TOP)
3	2	SPRG-ROLLER/TE/TT	ROLLER SPRING REV 4
4	2	RM-#6-32/TE/3/16	#6-32 X 3/16
5	1	RM-TICTEX/TE/ENTR	TT1000 ENTRANCE BLOCK
6	1	BLOK-TT/FRONT	CENTER SPACE BLOCK
7	1	BLOK-TTCEML	CENTER SPACER BLOCK W/ MILL
8	2	RM-SPRGEN	ENTRANCE BLOCK PIANO SPRING
9	2	RM-#10-24 X 3/4	ENTRANCE BLOCK SHOULDER SCREW
10	4	RM-SPRPIN/ 3/4	SPRING PIN 5/32 X 3/4 LG
11	2	ROLR-ASSM/TE/IDLR	IDLER ROLLER ASSY
12	4	RM-#6-32S/TT/3/8	#6-32 TAMPERPROOF SCREW
13	4	RM-#6-32C/TE/1/2	#6-32 X 1/2 SHCS
14	6	RM-#6LOCW/AD/	#6 LOCKWASHER
15	4	RM-#6-32/TE/3/8	#6-32 X 3/8 SHCS
16	2	SCRW-TT1000/TT/BARC	MALE/FEM HEX THRD STANDOFF
17	1	BAR CODE READ PCB	CHECK REV
18	2	SPAC-STOPPR/TT/GUIDE	STOPPER FOR GUIDE ASSY

NOTE: ITEMS 16 (THUMB SCREWS) AND 17 (PRINTED CIRCUIT BOARD) ARE NOT INCLUDED IN ASSEMBLY.

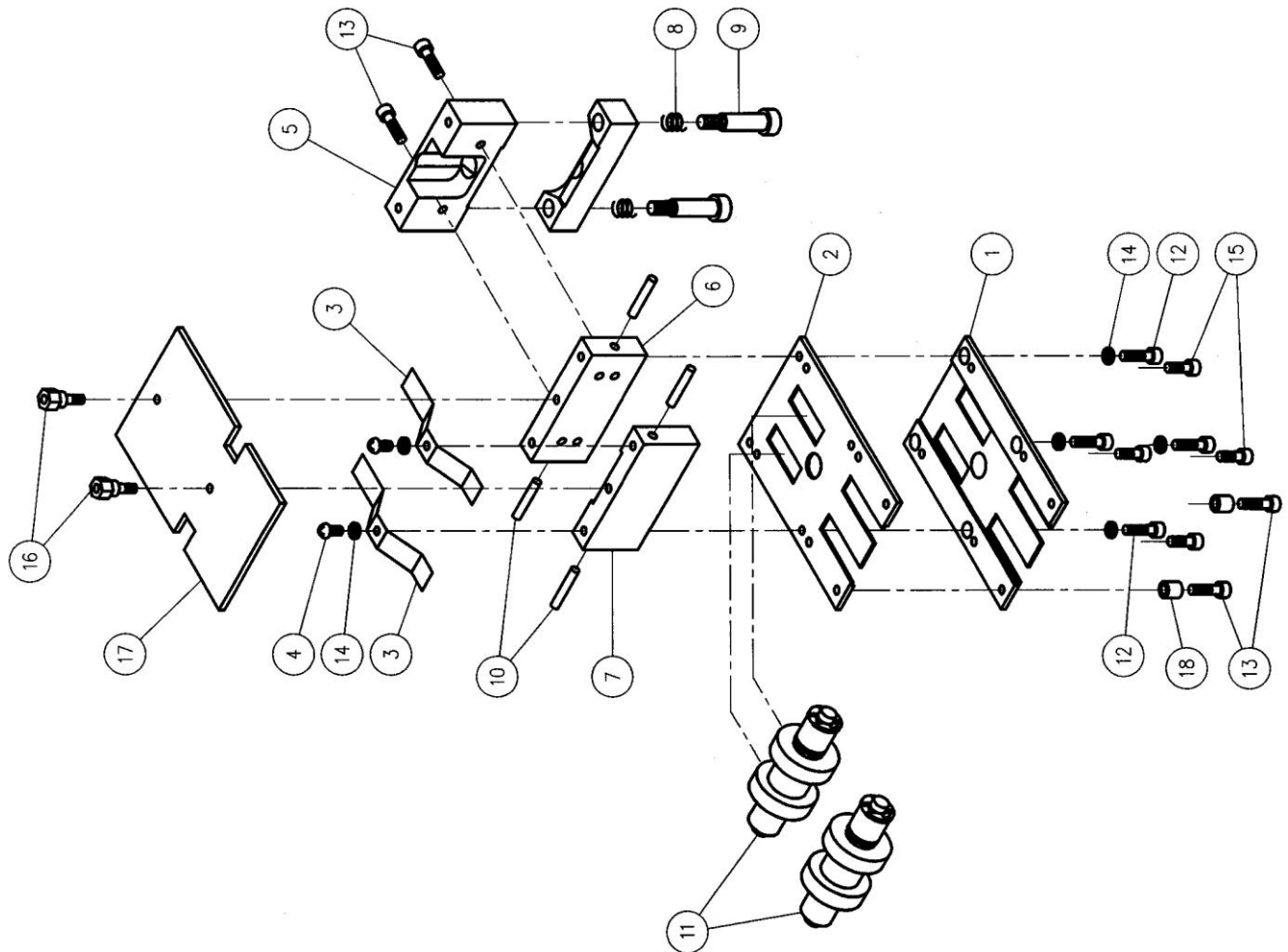

REV	DATE	DESCRIPTION
B	10/17/02	REVISED & REDRAWN
REV	DATE	DESCRIPTION
DRAWN	DATE	
PGS	2/2/00	
CHECK	DATE	
APPR	DATE	
COMPUTER GRAPHICS MANUAL CHANGES RESTRICTED		
 <b>Deltronic Labs, Inc.</b> 120 Liberty Lane, Chalfont, PA TICKET EATER GUIDE ASSEMBLY EXPLODED VIEW		
GUID-TT2000/TT/		B

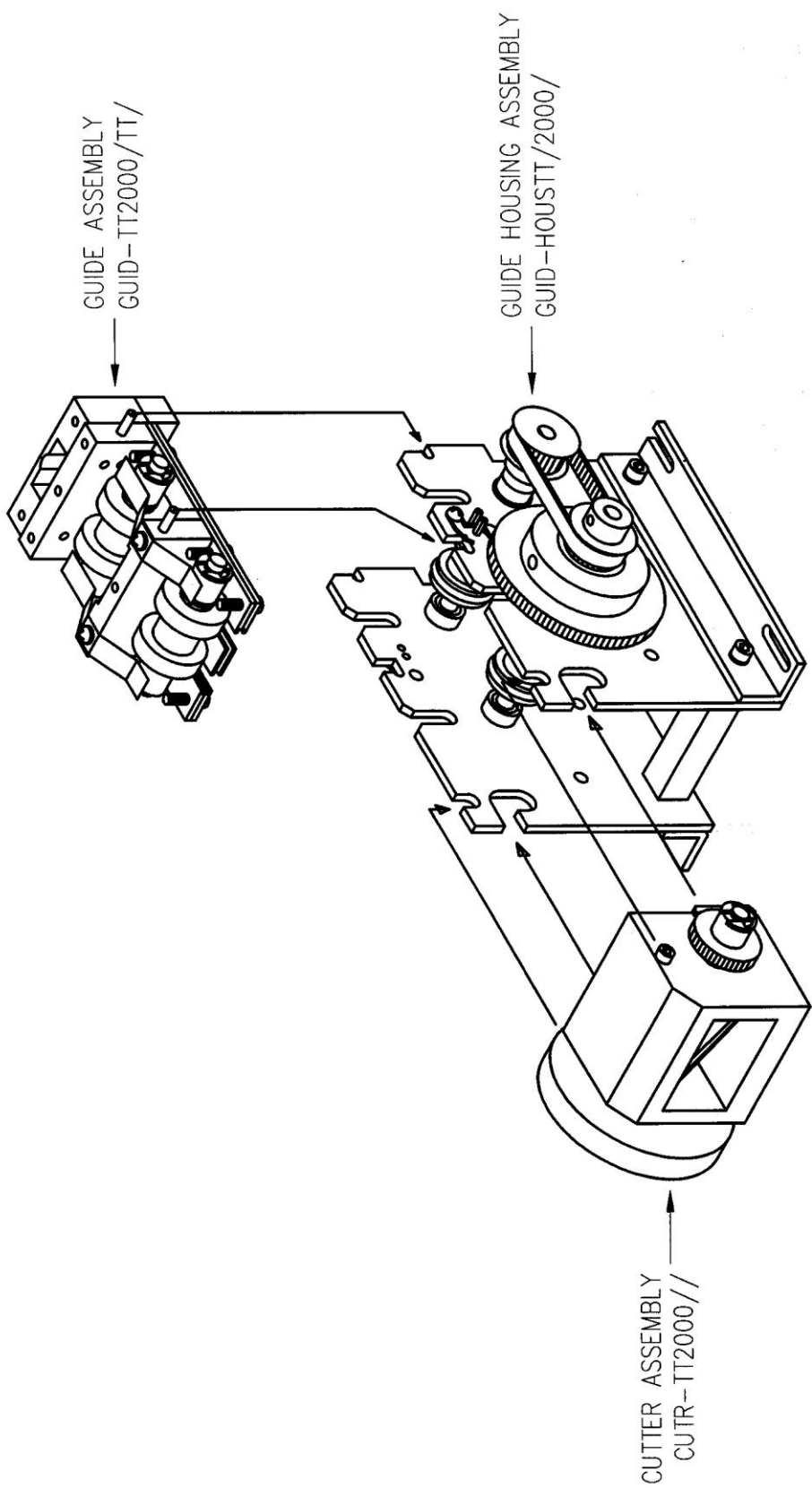

**NOTES:**

1. REFER TO PAGE 11 FOR DETAILS ON GUIDE ASSEMBLY INSERTION.
2. BE SURE THE CUTTER ASSEMBLY IS PUSHED ALL THE WAY DOWN AND GEARS ARE MESHED PROPERLY.

REV	DATE	DESCRIPTION
B	10/17/02	REVISED & REDRAWN
DRAWN DATE		 <b>Deltronic Labs, Inc.</b> 120 Liberty Lane, Chalfont, PA
FW	2/2/00	
CHECK DATE		TICKET EATER GUIDE ASSEMBLY INSERTION
APPR DATE		EXPLODED VIEW
COMPUTER GRAPHICS		GUID-TT2000/TT/
MANUAL CHANGES		
RESTRICTED		B

ASSY # GUID-HOUSTT/2000/ (CONTINUED)		
ITEM	QTY	DL PART # DESCRIPTION
20	1	RM-MOTBOD MOTOR (NOT SHOWN)
21	1	SPAC-SP242/TT/CLCH MOTOR COUPLING SPACER
22	2	SPRG-FRONTIP/TD/ SPRING FOR FRONT TD PANEL
23	4	RM-SPRPN/5/16 ø3/32 X 5/16 SPRING PIN
24	2	RM-4-40T/TD/1/8 #4-40 X 1/8 TRUSS HEAD SCREW
25	1	RM-CLUTCH/TT/ SLIP COUPLING (STANDARD)
25*	1	SET-COUPLING "LOVEJOY" COUPLING (SPECIAL ORDER)

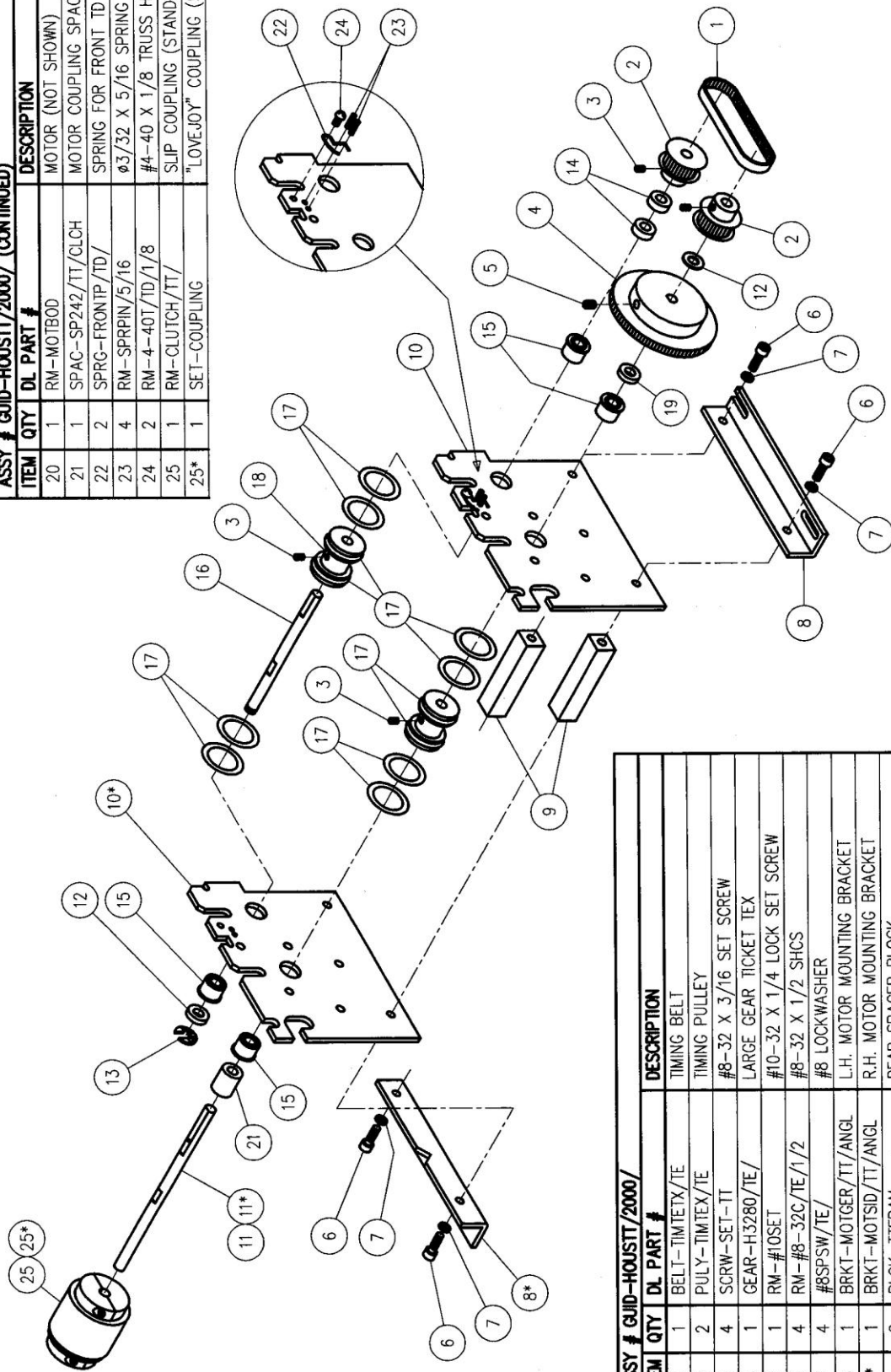

ASSY # GUID-HOUSTT/2000/		
ITEM	QTY	DL PART # DESCRIPTION
1	1	BELT-TIMTEX/TE TIMING BELT
2	2	PULY-TIMTEX/TE TIMING PULLEY
3	4	SCRW-SET-TT #8-32 X 3/16 SET SCREW
4	1	GEAR-H3280/TE/ LARGE GEAR TICKET TEX
5	1	RM-#10SET #10-32 X 1/4 LOCK SET SCREW
6	4	RM-#8-32C/TE/1/2 #8-32 X 1/2 SHCS
7	4	#8SPSW/TE/ #8 LOCKWASHER
8	1	BRKT-MOTGR/TT/ANGL L.H. MOTOR MOUNTING BRACKET
8*	1	BRKT-MOTSID/TT/ANGL R.H. MOTOR MOUNTING BRACKET
9	2	BLOK-TIFRAM REAR SPACER BLOCK
10	1	RM-SDPTIL SIDE PLATE LEFT SIDE
10*	1	RM-SDPTIR SIDE PLATE RIGHT SIDE
11	1	SHFT-CLUTCH/ MOTOR DRIVESHAFT (SLIP COUPLING)
11*	1	RMSHFTDR/TT/ MOTOR DRIVESHAFT (LOVEJOY COUPLING)
12	2	SPAC-032/TT/WSHR SPACER WASHER
13	1	RING-E25RET/TT/ RETAINING RING
14	2	PULY-SP212/TE/NYLN NYLON SPACER
15	4	PSB-250 BRONZE PRESS-ALIGN BEARING
16	1	SHFT-TTDRV/TE/ TIC TEX DRIVE ROLLER SHAFT
17	12	RING-TICTEX/TE/ URETHANE O-RING
18	2	ROLL-DRIVE/TE/ T/E DRIVE ROLLER W/O PARTS
19	1	SPAC-093/TT/WSHR SPACER WASHER

REVISIONS	
REV	DESCRIPTION
B	10/17/02 REVISED & REDRAWN

REV	DATE	DESCRIPTION
DRAWN	DATE	
2/2/00		
CHECK	DATE	
APPR	DATE	

120 Liberty Lane, Chalfont, PA	
TICKET EATER GUIDE HOUSING ASSEMBLY EXPLODED VIEW	
COMPUTER GRAPHICS MANUAL CHANGES RESTRICTED	GUID-HOUSTT/2000/

ASSY # CUTR-TT2000//

ITEM	QTY	DL PART #	DESCRIPTION
1	1	RM-HOUSING/	HOUSING
2	1	RM-CUTBLD/TE	ROTATING CUTTER
3	1	RM-BLDSTN//	STATIONARY BLADE
4	1	SHFT-TT2CUT//	SHAFT
5	1	CUTR-WHEEL//	FLYWHEEL
6	1	GEAR-H3232/TE/	GEAR
7	2	RING-E25RET/TT//	RETAINING RING
8	2	BRNG-FF312	FLANGED BUSHING
9	2	BRNG-TT504	THRUST WASHER
10	2	RM-#6-32C//3/16	#6-32 X 3/16 SHCS
11	2	RM-#6-32C/E/3/8	#6-32 X 3/8 SHCS
12	2	RM-#6SET//1/4	#6-32 X 1/4 SET SCREW
13	3	RM-#10SET//	#10-32 X 3/16 SET SCREW

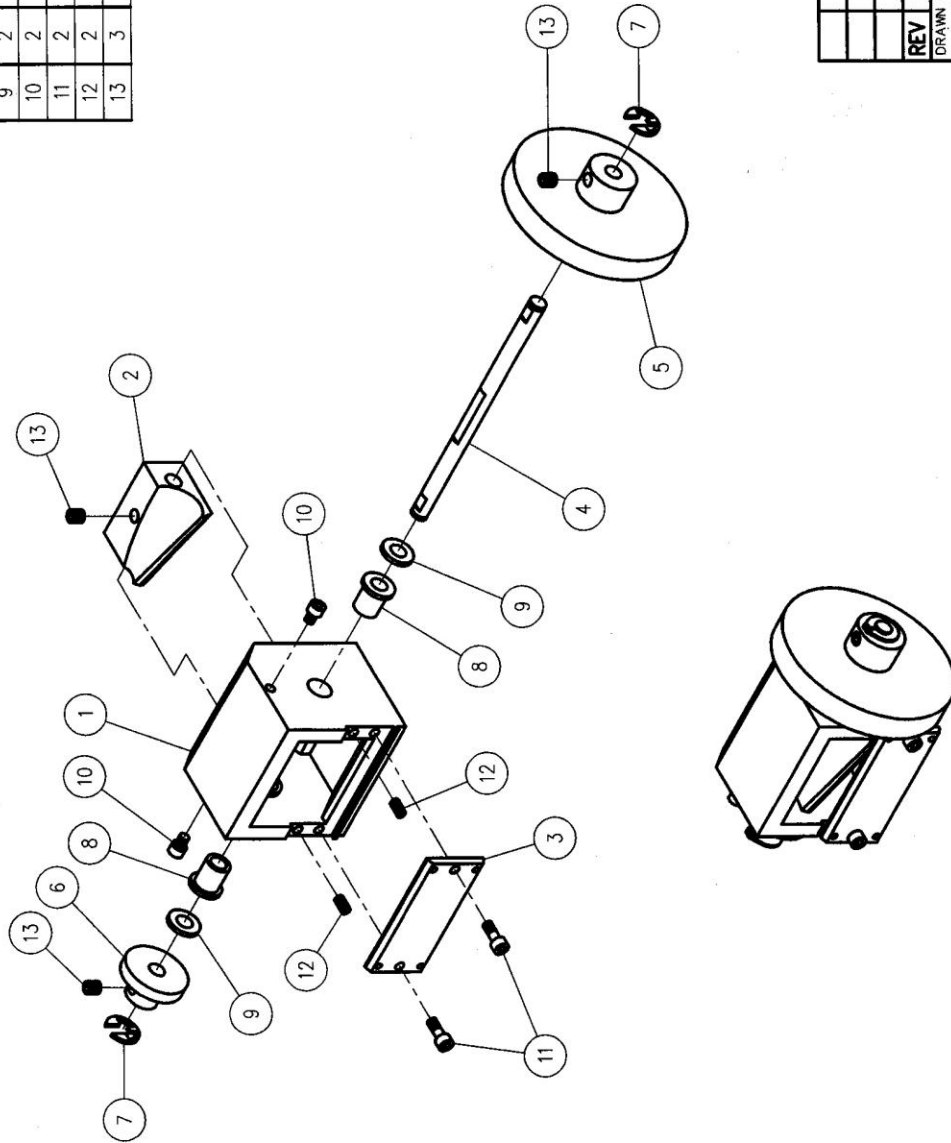

REV	DATE	DESCRIPTION
DRAWN	DATE	
10/17/02		
CHECK	DATE	
APPR	DATE	
COMPUTER GRAPHICS MANUAL CHANGES RESTRICTED		
Deltronic Labs, Inc. 120 Liberty Lane, Chalfont, PA		TICKET EATER CUTTER ASSEMBLY EXPLODED VIEW
CUTR-TT2000//		A

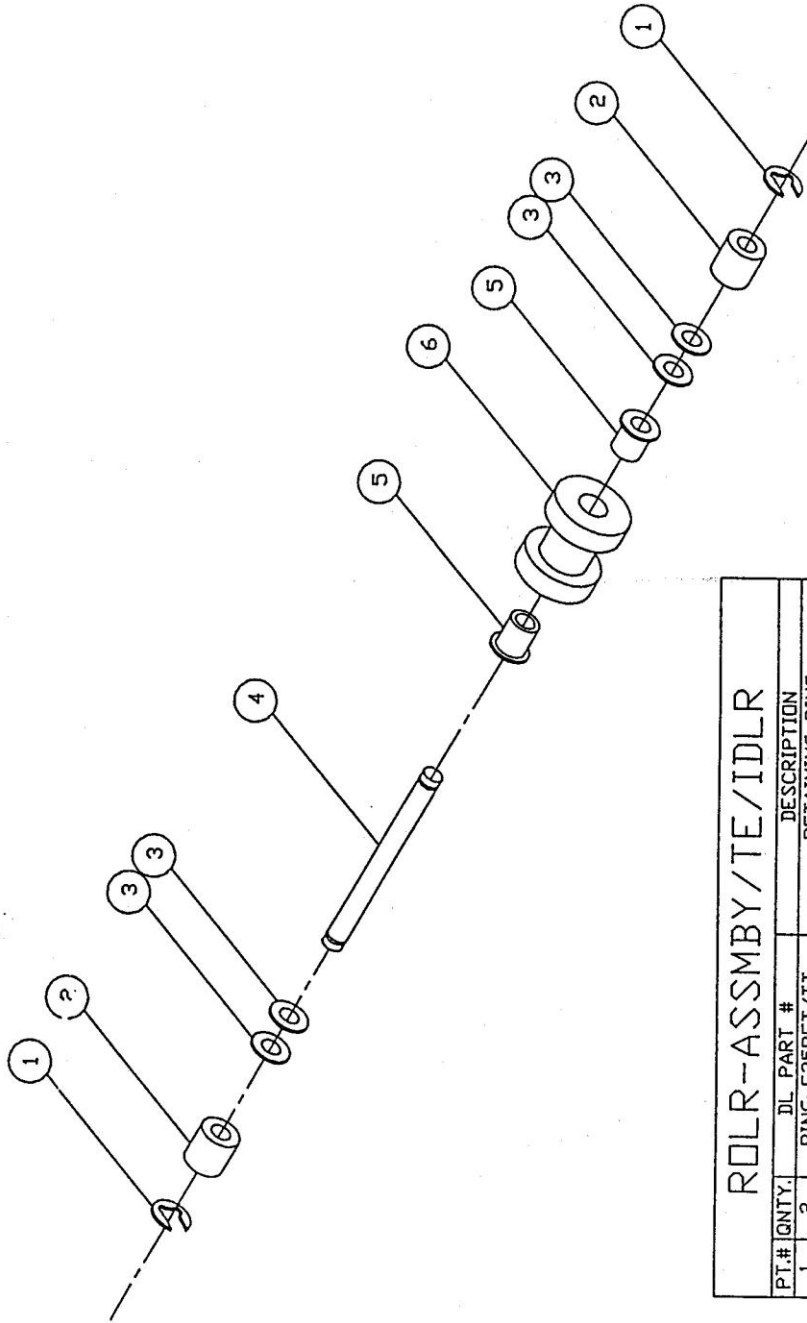

ROLLER-ASSMBY/TE/IDLR			
PT.#	QNTY.	DL PART #	DESCRIPTION
1	2	RING-E2SRET/TT	RETAINING RING
2	2	SPAC-232 IDLR	SPACER 232 IDLER ROLLER
3	4	SPAC-032/TT/WSHR	SPACER WASHER
4	1	SHFT-IDLR/TE/	TE IDLER ROLLER SHAFT
5	2	BRNG-F312	FLANGED BRONZE BEARING
6	1	RM-RLRIDL/TE/	IDLER ROLLER

PG. (20)	ROLLER ASSM. EXPLODED VIEW
DRAWN BY	DANIEL P CARLIN
DATE	2/2/00
REVISIONS:	

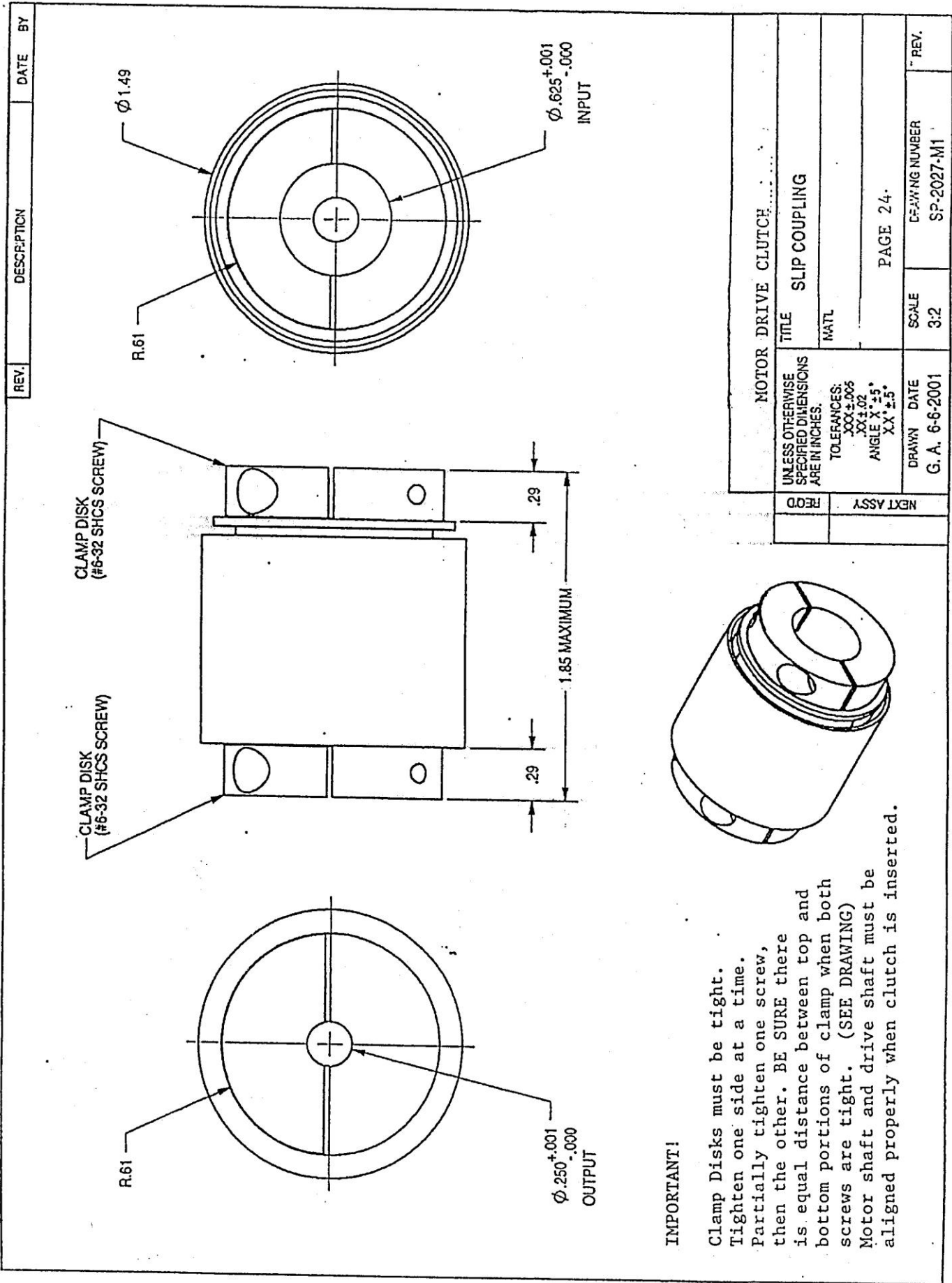

MOTOR DRIVE CLUTCH	
UNLESS OTHERWISE SPECIFIED DIMENSIONS ARE IN INCHES.	TITLE SLIP COUPLING
TOLERANCES: .XXX ± .005 .XX ± .02 ANGLE X° ± .5° XX' ± .5°	MATL
DRAWN DATE G. A. 6-6-2001	SCALE 3:2
NEXT ASSY	DRAWING NUMBER SP-2027-M1
REV.	REV.

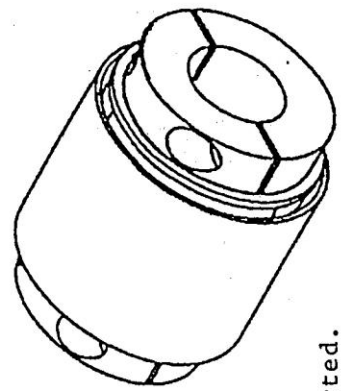

**IMPORTANT!**

Clamp Disks must be tight. Tighten one side at a time. Partially tighten one screw, then the other. BE SURE there is equal distance of clamp when both bottom portions of clamp when both screws are tight. (SEE DRAWING) Motor shaft and drive shaft must be aligned properly when clutch is inserted.

## Sensor Boards

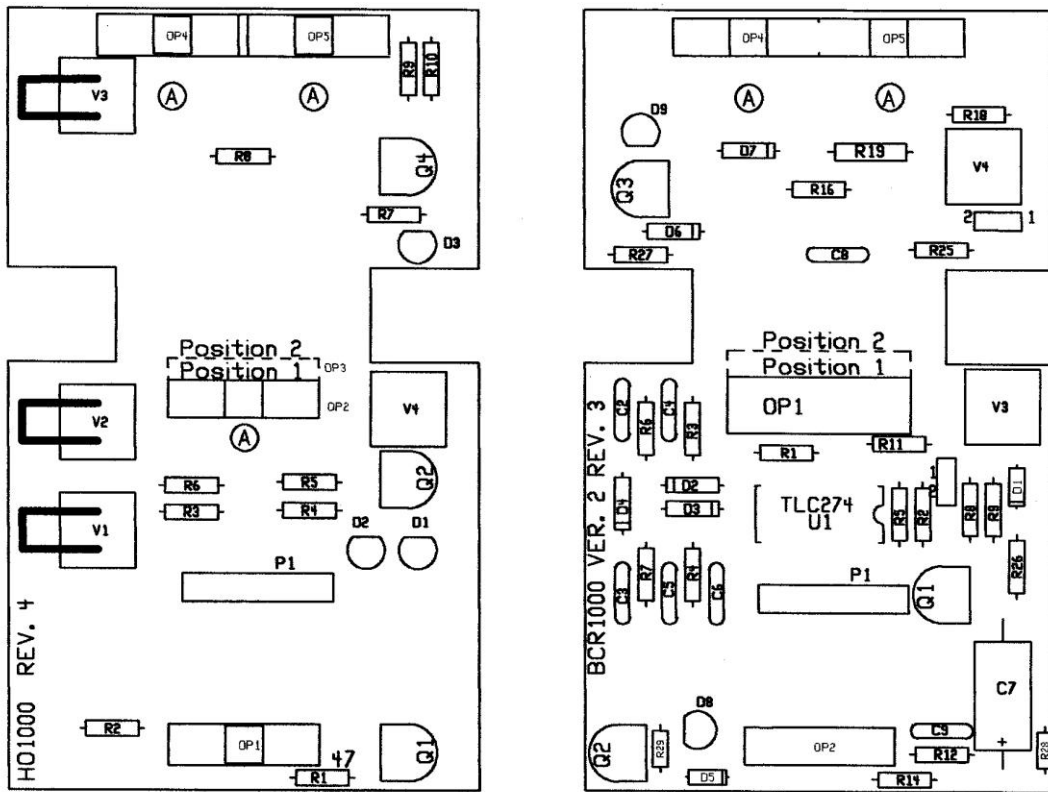

**NOTE:** For HO-1000 Rev.4 OP2 = Position 1, OP3 = Position 2  
 For BCR-1000 Rev.3 OP1, Use Position 1 or 2  
 For Ticket guide assemblies with **OVAL** cutouts use Position 1 or 2.  
 For Ticket guide assemblies with **ROUND** cutouts use: Position 1 **ONLY**.  
 (Middle Sensors Only)

**IMPORTANT:** For Sensor Replacement:

Scanner PCB's BCR-1000 Rev. 2 & 3 and HO-1000 Rev. 4, have sensor "L" bracket mounting holes marked "A" (Marked on drawing only)  
**Use only when replacing middle or rear sensors.**  
 Other sensors use PCB mounted "studs" to brace sensors.

When replacing sensors, note Rev.# on PCB. If mounting holes do not exist, remove brackets before mounting. **(Insert sensors to same depth and direction as all others).**

**SENSOR PLACEMENT:** Each scanner PCB has specific sensors in certain locations.

**For HO-1000- All Revs. USE:**

VTR16DI- ("V" shaped Lens) OP4 and OP5 **ONLY** (can be used in OP1)  
 QRB1114- (Flat Lens) OP1 and OP2-3 **ONLY**

**For BCR-1000- All Revs. USE:**

VTR16DI- ("V" shaped Lens) OP2, OP4 and OP5  
 QRB1114- (Flat Lens) Can be used in OP2 **ONLY**

**NOTE:** For BCR-1000 PCB, All Revs. OP1 is OTC680 **ONLY**

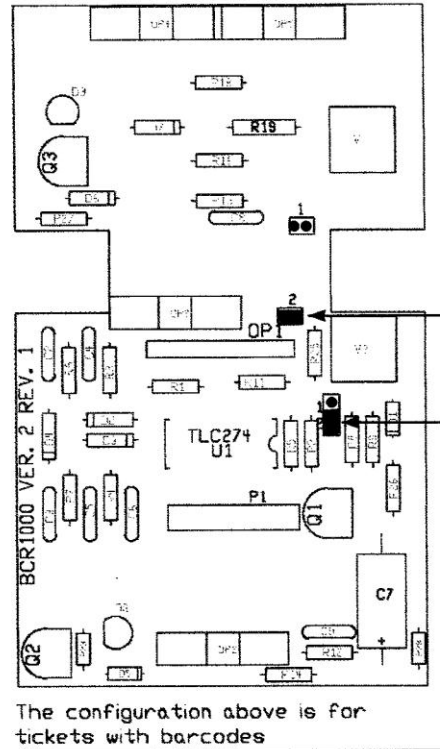
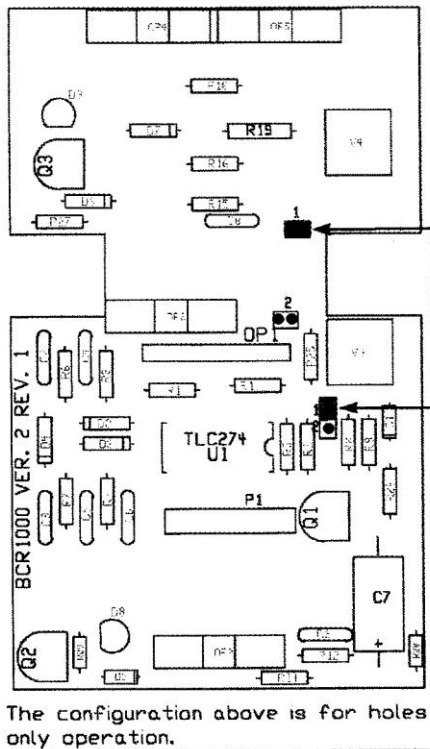

**BCR1000 Rev. 1**

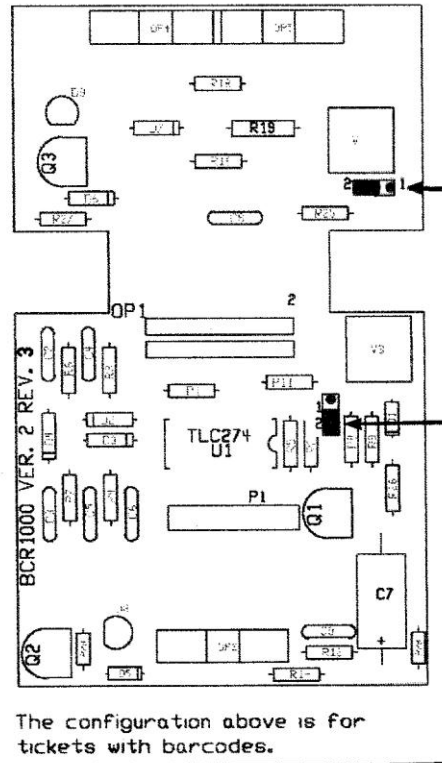
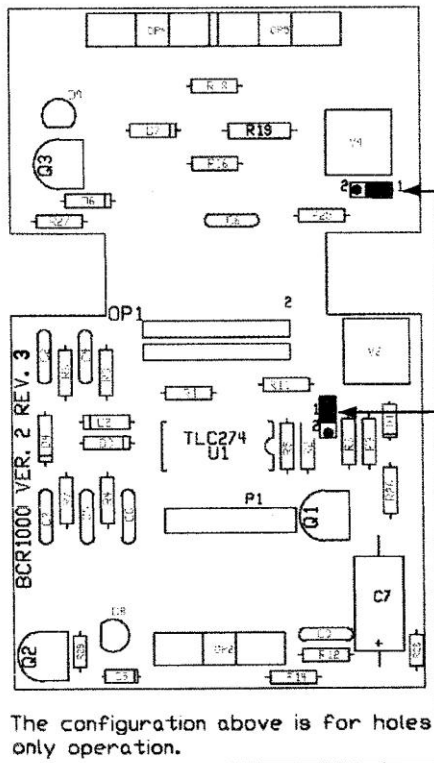

**BCR1000 Rev. 3-4**

These drawings show configurations for BCR1000 sensor board revisions that can be configured to read barcoded or holes-only tickets. The top drawings are for revision V2R1; the bottom are for revisions V2R3 & V2R4. The drawings on the right show the jumper positions for barcoded tickets. Those on the left are for holes-only tickets. Holes-only operation is intended for emergency situations only. Note that the logic board options must also be changed to match the jumpers. Version 5 BCR1000 boards can not be configured as holes-only boards.

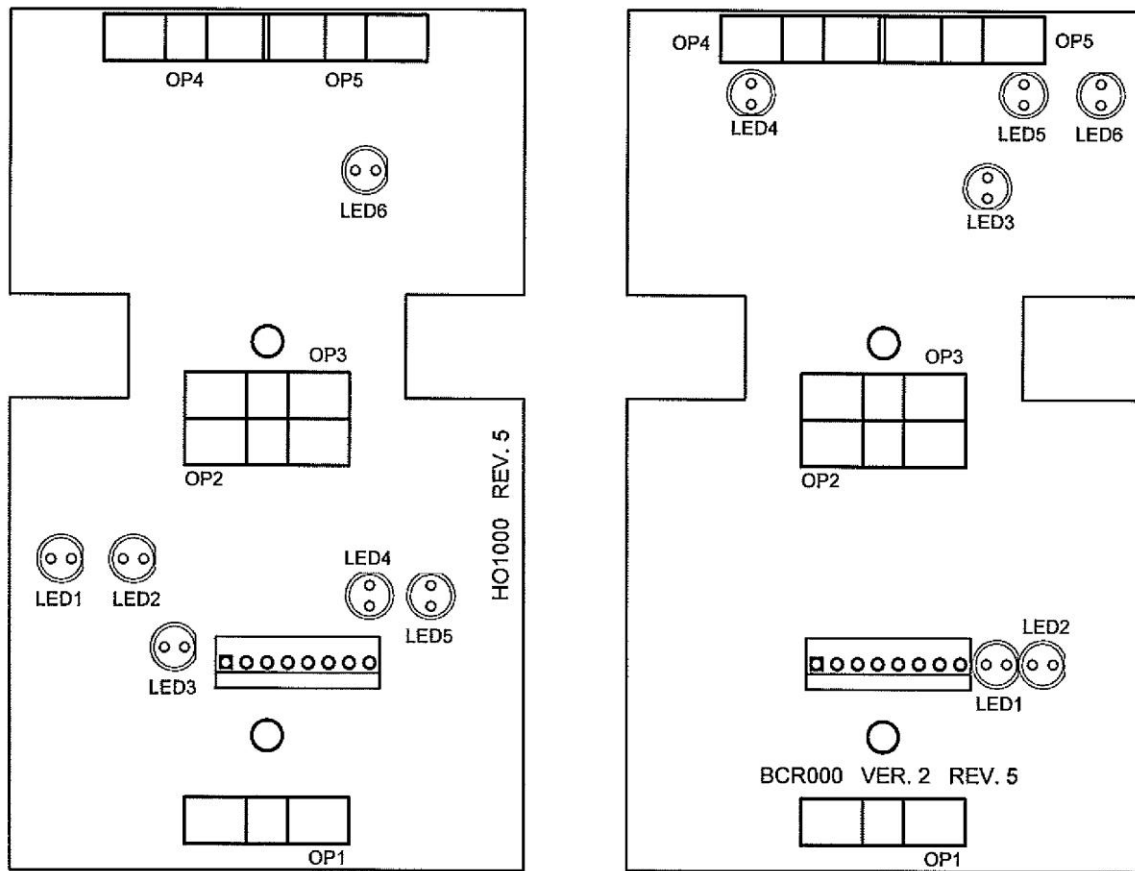

The Rev. 5 sensor boards have 6 LED's and 5 sensors. There is an LED for each sensor, and an LED to indicate a cheating or an error condition. The front sensor detects the ticket to turn the motor on. The middle sensors work together to count the tickets and detect cheating. The rear sensors provide additional cheat detection.

HO-1000		
SENSOR	LED	NOTES
Front	4	On when sees ticket
Middle Front	1	On when sees ticket
Middle Rear	6	On when sees ticket
Rear Left	3	On when sees ticket
Rear Right	2	On when sees ticket
	5	Flashes on for error or cheating

BCR-1000		
SENSOR	LED	NOTES
Front	2	On when sees ticket
Middle Front	3	On and off as it sees ticket and barcode
Middle Rear	4	On when sees ticket
Rear Left	5	On when sees ticket
Rear Right	6	On when sees ticket
	1	Flashes on for error or cheating

# Electrical Schematics

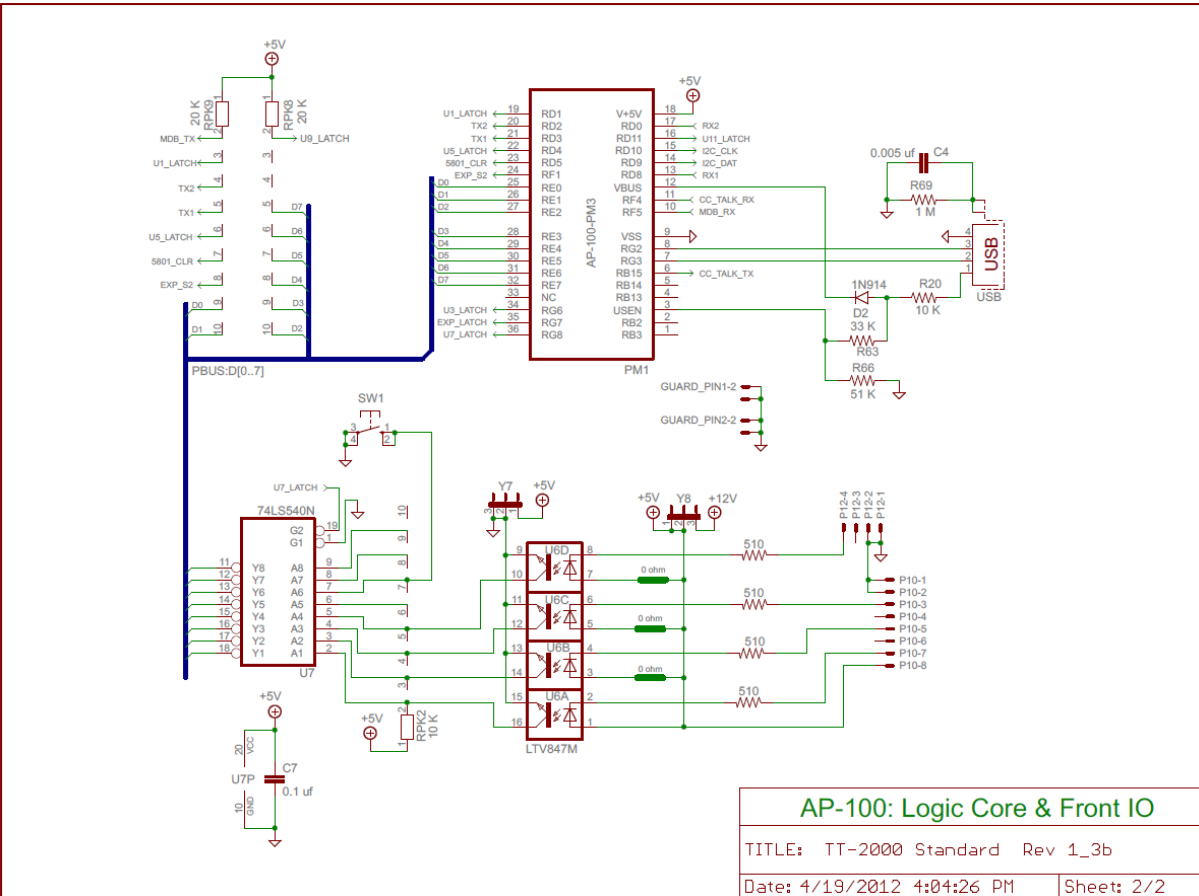
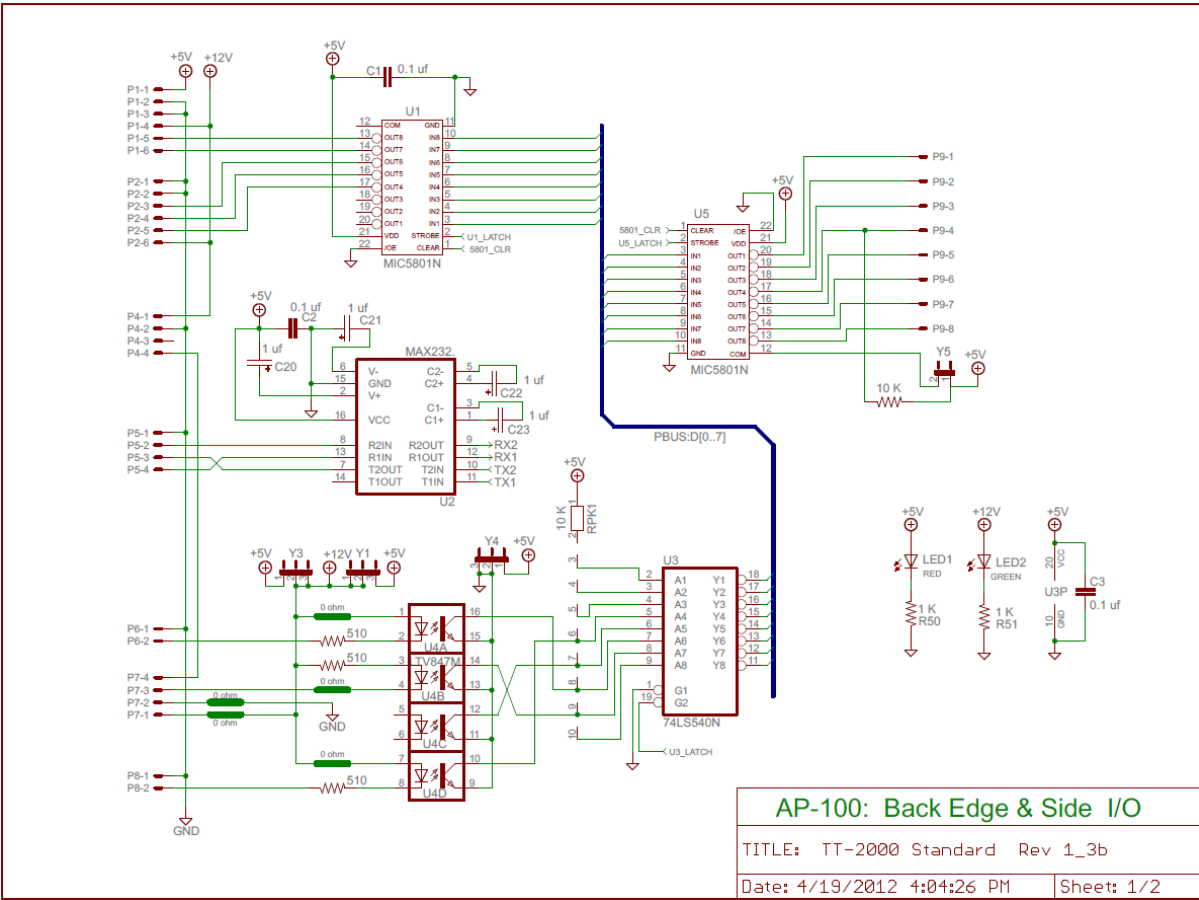

# TTEX DC HARNESS STANDARD VERSION

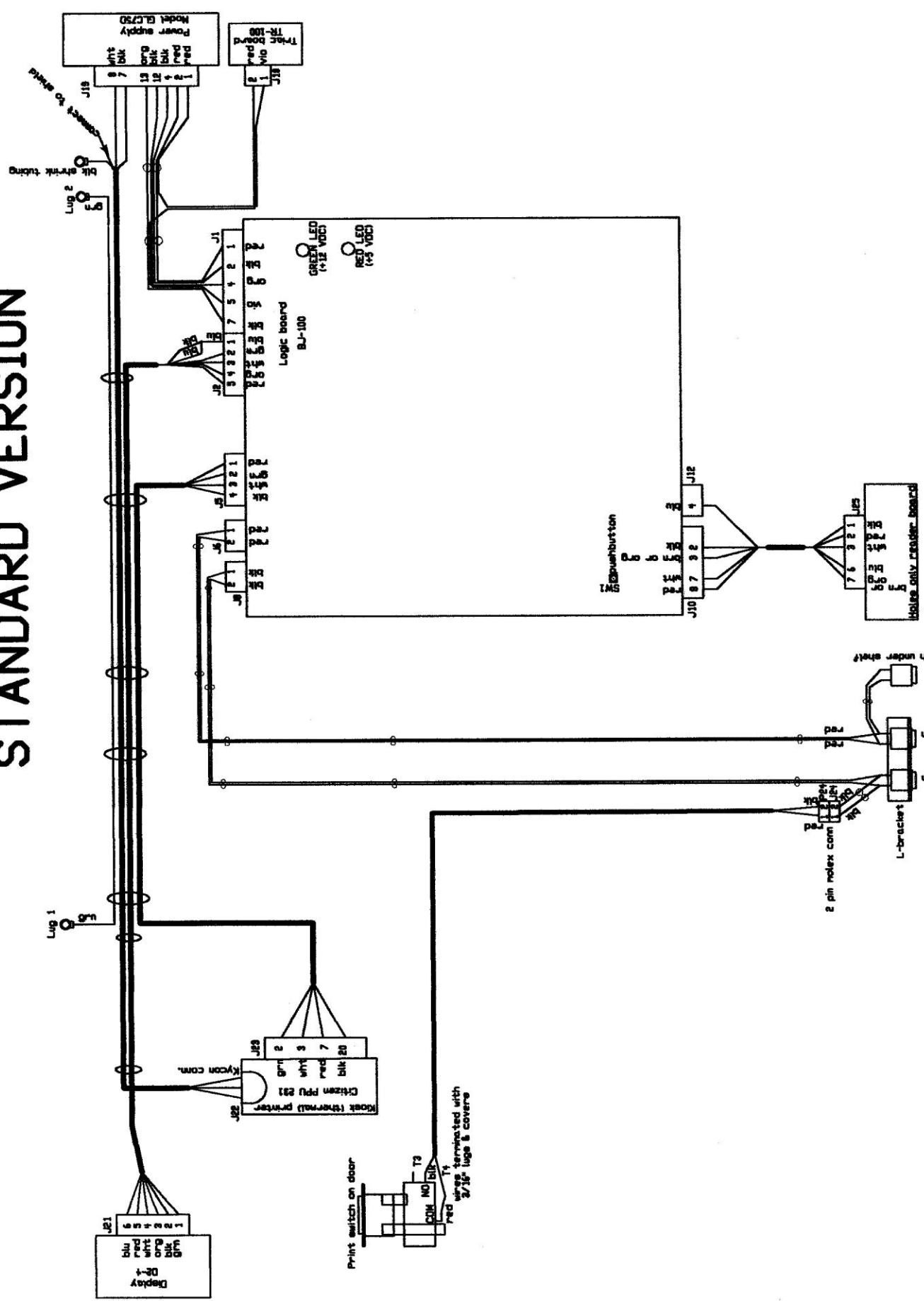

# TTEX AC HARNESS STANDARD & DKS VERSION

NOTE: WIRE COVERS ARE CLEAR EXCEPT WHERE NOTED

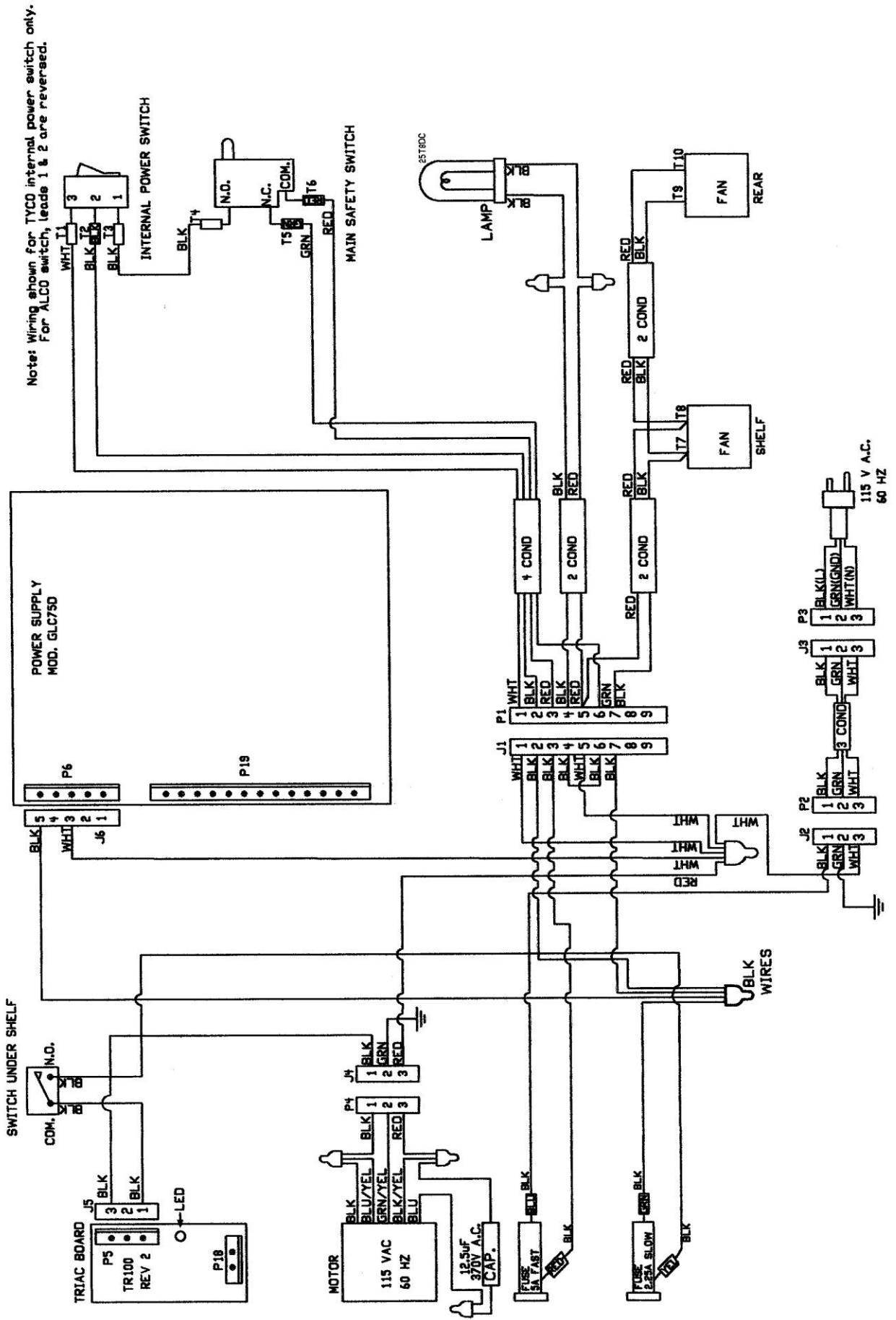

## Warranty Information

---

Deltronic Labs, Inc. will replace or repair any mechanical or electronic parts damaged as a result of component or circuit failure. We will also repair or replace defects in parts or assembly caused by normal operations.

Deltronic Labs, Inc. will not, however, be responsible for damage caused by or due to misuse of operation or power requirements, including system overloads or modification and burn out of electronic boards. Nor will Deltronic Labs, Inc. be responsible for visible damage or broken or missing parts caused by tampering with the units or unauthorized servicing.

Warranties are as follows:

Electronic Components (boards, displays, power supplies, etc.) – One year warranty\*.

Mechanical Parts & Assemblies – 90 Day Warranty\*.

\*Please note that the warranty start date is the actual ship date.